

MiTek, Inc.
400 Sunrise Ave., Suite 270
Roseville, CA 95661
916.755.3571

Re: J1183948

NW Eastside Builders LLC

The truss drawing(s) referenced below have been prepared by MiTek USA, Inc. under my direct supervision based on the parameters provided by The Truss Company (Sumner, WA).

Pages or sheets covered by this seal: R90572879 thru R90572919

My license renewal date for the state of Washington is September 28, 2027.



October 3, 2025

Zhao, Xiaoming

IMPORTANT NOTE: The seal on these truss component designs is a certification that the engineer named is licensed in the jurisdiction(s) identified and that the designs comply with ANSI/TPI 1. These designs are based upon parameters shown (e.g., loads, supports, dimensions, shapes and design codes), which were given to MiTek or TRENCO. Any project specific information included is for MiTek's or TRENCO's customers file reference purpose only, and was not taken into account in the preparation of these designs. MiTek or TRENCO has not independently verified the applicability of the design parameters or the designs for any particular building. Before use, the building designer should verify applicability of design parameters and properly incorporate these designs into the overall building design per ANSI/TPI 1, Chapter 2.

Job J1183948	Truss A01	Truss Type Roof Special Supported Gable	Qty 1	Ply 1	NW Eastside Builders LLC Job Reference (optional)	R90572879
-----------------	--------------	--	----------	----------	--	-----------

The Truss Company (Sumner, WA), Sumner, WA - 98390,

Run: 25.30 S Sep 17 2025 Print: 25.3.0 S Sep 17 2025 MiTek Industries, Inc. Thu Oct 02 17:24:46
ID:PyZoY4Y3qctXRL7glpfJKJz980y-RfC?PsB70Hq3NSgPqnL8w3uTXbGKwRCDoi7J4zJC?f

Page: 1

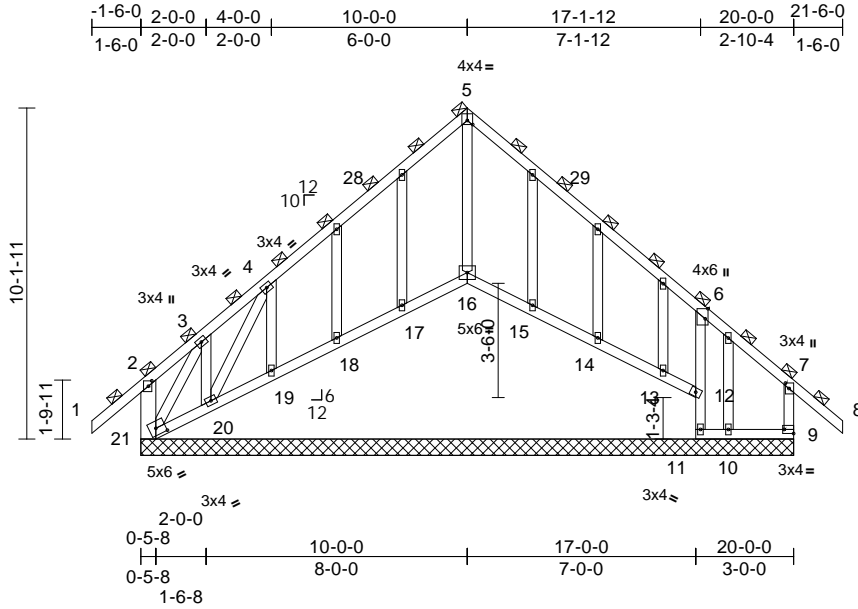

Scale = 1:70.6

Plate Offsets (X, Y): [2:0-2-0,0-1-4], [5:0-2-0,0-1-8], [6:0-3-11,Edge], [7:0-2-0,0-1-4], [9:Edge,0-1-8], [21:0-3-8,0-2-8]

Loading	(psf)	Spacing	2-6-0	CSI	DEFL	in	(loc)	l/defl	L/d	PLATES	GRIP	
TCLL	25.0	Plate Grip DOL	1.15	TC	0.78	Vert(LL)	n/a	-	n/a	999	MT20	185/148
(Roof Snow = 25.0)		Lumber DOL	1.15	BC	0.56	Vert(CT)	n/a	-	n/a	999		
TCDL	8.0	Rep Stress Incr	NO	WB	0.33	Horz(CT)	0.02	9	n/a	n/a		
BCLL	0.0*	Code	IRC2021/TPI2014	Matrix-MS								
BCDL	7.0											
											Weight: 127 lb	FT = 20%

LUMBER
TOP CHORD 2x4 HF-N No.1/No.2
BOT CHORD 2x4 HF-N No.1/No.2
WEBS 2x4 DF Stud *Except* 21-2:2x6 DF SS
OTHERS 2x4 DF Stud

BRACING
TOP CHORD 2-0-0 oc purlins (6-0-0 max.), except end verticals
(Switched from sheathed: Spacing > 2-0-0).
BOT CHORD Rigid ceiling directly applied or 10-0-0 oc bracing, Except:
6-0-0 oc bracing: 20-21.

REACTIONS (size)
9=20-0-0, 10=20-0-0, 11=20-0-0, 12=20-0-0, 13=20-0-0, 14=20-0-0, 15=20-0-0, 16=20-0-0, 17=20-0-0, 18=20-0-0, 19=20-0-0, 20=20-0-0, 21=20-0-0
Max Horiz 21=-255 (LC 8)
Max Uplift 9=-10 (LC 7), 10=-159 (LC 6), 11=-69 (LC 9), 12=-487 (LC 11), 13=-67 (LC 1), 16=-56 (LC 9), 19=-15 (LC 8), 20=-856 (LC 10), 21=-336 (LC 8)
Max Grav 9=478 (LC 1), 10=129 (LC 9), 11=111 (LC 6), 12=670 (LC 19), 13=53 (LC 3), 14=90 (LC 3), 15=87 (LC 3), 16=337 (LC 18), 17=89 (LC 3), 18=85 (LC 3), 19=92 (LC 10), 20=911 (LC 18), 21=495 (LC 7)

FORCES (lb) - Maximum Compression/Maximum Tension
TOP CHORD 2-21=-304/260, 1-2=0/91, 2-3=-79/80, 3-4=-689/512, 4-5=-570/174, 5-6=-609/160, 6-7=-258/75, 7-8=0/87, 7-9=-368/31

BOT CHORD 20-21=-221/461, 19-20=-98/351, 18-19=-106/353, 17-18=-105/350, 16-17=-106/349, 15-16=-105/349, 14-15=-105/349, 13-14=-102/355, 12-13=-112/316, 11-12=0/0, 6-12=-647/396, 10-11=-87/161, 9-10=-87/161
WEBS 3-21=-831/590, 4-20=-1061/850

NOTES
1) Wind: ASCE 7-16; Vult=110mph (3-second gust) Vasd=87mph; TCDL=4.8psf; BCDL=4.2psf; h=25ft; Cat. II; Exp B; Partially Enclosed; MWFRS (envelope) exterior zone and C-C Exterior(2E) -1-6-0 to 1-9-2, Interior (1) 1-9-2 to 7-0-0, Exterior(2R) 7-0-0 to 13-0-0, Interior (1) 13-0-0 to 18-6-0, Exterior(2E) 18-6-0 to 21-6-0 zone; cantilever left and right exposed; end vertical left and right exposed; C-C for members and forces & MWFRS for reactions shown; Lumber DOL=1.60 plate grip DOL=1.60
2) Truss designed for wind loads in the plane of the truss only. For studs exposed to wind (normal to the face), see Standard Industry Gable End Details as applicable, or consult qualified building designer as per ANSI/TPI 1.
3) TCLL: ASCE 7-16; Pf=25.0 psf (Lum DOL = 1.15 Plate DOL = 1.15); Is=1.0; Rough Cat B; Partially Exp.; Ce=1.0; Cs=1.00; Ct=1.10
4) This truss has been designed for greater of min roof live load of 16.0 psf or 1.00 times flat roof load of 25.0 psf on overhangs non-concurrent with other live loads.
5) All plates are 2x4 (||) MT20 unless otherwise indicated.
6) Gable requires continuous bottom chord bearing.
7) Truss to be fully sheathed from one face or securely braced against lateral movement (i.e. diagonal web).
8) Gable studs spaced at 2-0-0 oc.
9) This truss has been designed for a 10.0 psf bottom chord live load nonconcurrent with any other live loads.

10) * This truss has been designed for a live load of 20.0psf on the bottom chord in all areas where a rectangle 3-06-00 tall by 2-00-00 wide will fit between the bottom chord and any other members.
11) Bearing at joint(s) 21, 12 considers parallel to grain value using ANSI/TPI 1 angle to grain formula. Building designer should verify capacity of bearing surface.
12) Provide mechanical connection (by others) of truss to bearing plate capable of withstanding 336 lb uplift at joint 21, 56 lb uplift at joint 16, 487 lb uplift at joint 12, 69 lb uplift at joint 11, 10 lb uplift at joint 9, 15 lb uplift at joint 19, 856 lb uplift at joint 20, 67 lb uplift at joint 13 and 159 lb uplift at joint 10.
13) Beveled plate or shim required to provide full bearing surface with truss chord at joint(s) 16, 17, 18, 19, 20, 15, 14, 13.
14) Graphical purlin representation does not depict the size or the orientation of the purlin along the top and/or bottom chord.

LOAD CASE(S) Standard



October 3, 2025

WARNING - Verify design parameters and READ NOTES ON THIS AND INCLUDED MITEK REFERENCE PAGE MII-7473 rev. 1/2/2023 BEFORE USE.

Design valid for use only with MiTek® connectors. This design is based only upon parameters shown, and is for an individual building component, not a truss system. Before use, the building designer must verify the applicability of design parameters and properly incorporate this design into the overall building design. Bracing indicated is to prevent buckling of individual truss web and/or chord members only. Additional temporary and permanent bracing is always required for stability and to prevent collapse with possible personal injury and property damage. For general guidance regarding the fabrication, storage, delivery, erection and bracing of trusses and truss systems, see **ANSI/TPI1 Quality Criteria and DSB-22** available from Truss Plate Institute (www.tpinst.org) and **BCSI Building Component Safety Information** available from the Structural Building Component Association (www.sbcsccomponents.com)

MiTek®

400 Sunrise Ave., Suite 270
Roseville, CA 95661
916.755.3571 / MiTek-US.com

Job J1183948	Truss A02	Truss Type Roof Special	Qty 1	Ply 1	NW Eastside Builders LLC Job Reference (optional)	R90572880
-----------------	--------------	----------------------------	----------	----------	--	-----------

The Truss Company (Sumner, WA), Sumner, WA - 98390,

Run: 25.30 S Sep 17 2025 Print: 25.30 S Sep 17 2025 MiTek Industries, Inc. Thu Oct 02 17:24:47
ID:LiqgYy6JCxEU7?b4VWT4jz9C3k-RfC?PsB70Hq3NSgPqnL8w3uITxbGKwRCDoi7J4zJC?f

Page: 1

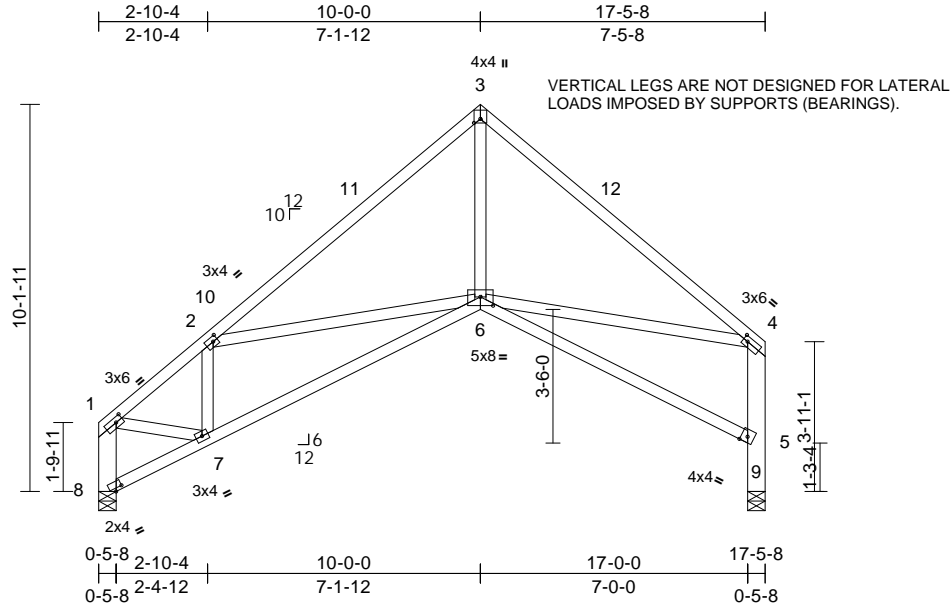

Scale = 1:60.4
Plate Offsets (X, Y): [1:0-2-4,0-1-8], [2:0-1-8,0-1-8], [3:0-1-4,0-2-0], [4:0-1-8,0-1-8], [6:0-4-0,0-2-12], [8:0-2-6,0-1-0]

Loading	(psf)	Spacing	2-0-0	CSI	DEFL	in	(loc)	l/defl	L/d	PLATES	GRIP	
TCLL (Roof Snow = 25.0)	25.0	Plate Grip DOL	1.15	TC	0.67	Vert(LL)	-0.09	5-6	>999	240	MT20	185/148
TCDL	8.0	Lumber DOL	1.15	BC	0.30	Vert(CT)	-0.16	5-6	>999	180		
BCLL	0.0*	Rep Stress Incr	YES	WB	0.24	Horz(CT)	0.06	9	n/a	n/a		
BCDL	7.0	Code	IRC2021/TPI2014	Matrix-MS								
											Weight: 96 lb	FT = 20%

LUMBER
TOP CHORD 2x4 HF-N No.1/No.2
BOT CHORD 2x4 HF-N No.1/No.2
WEBS 2x4 DF Stud *Except* 8-1,9-4:2x6 DF SS

BRACING
TOP CHORD Structural wood sheathing directly applied or 3-10-14 oc purlins, except end verticals.
BOT CHORD Rigid ceiling directly applied or 6-0-0 oc bracing.

REACTIONS (size) 8=0-5-8, 9=0-5-8
Max Horiz 8=200 (LC 9)
Max Uplift 8=-88 (LC 10), 9=-102 (LC 10)
Max Grav 8=680 (LC 1), 9=680 (LC 1)

FORCES (lb) - Maximum Compression/Maximum Tension
TOP CHORD 1-2=-893/166, 2-3=-946/121, 3-4=-942/120,
1-8=-673/106, 5-9=-680/102, 4-5=-672/142
BOT CHORD 7-8=-229/202, 6-7=-265/917, 5-6=-91/143
WEBS 3-6=-38/584, 2-7=-387/154, 1-7=-143/721,
2-6=-188/261, 4-6=-62/550

- NOTES**
- Wind: ASCE 7-16; Vult=110mph (3-second gust)
Vasd=87mph; TCDL=4.8psf; BCDL=4.2psf; h=25ft; Cat. II; Exp B; Partially Enclosed; MWFRS (envelope) exterior zone and C-C Exterior(2E) 0-2-12 to 3-2-12, Interior (1) 3-2-12 to 7-0-0, Exterior(2R) 7-0-0 to 13-0-0, Interior (1) 13-0-0 to 17-2-12 zone; cantilever left and right exposed; end vertical left and right exposed; C-C for members and forces & MWFRS for reactions shown; Lumber DOL=1.60 plate grip DOL=1.60
 - TCLL: ASCE 7-16; Pf=25.0 psf (Lum DOL = 1.15 Plate DOL = 1.15); Is=1.0; Rough Cat B; Partially Exp.; Ce=1.0; Cs=1.00; Ct=1.10
 - This truss has been designed for a 10.0 psf bottom chord live load nonconcurrent with any other live loads.

- * This truss has been designed for a live load of 20.0psf on the bottom chord in all areas where a rectangle 3-06-00 tall by 2-00-00 wide will fit between the bottom chord and any other members.
- Bearing at joint(s) 8, 9 considers parallel to grain value using ANSI/TPI 1 angle to grain formula. Building designer should verify capacity of bearing surface.
- Provide mechanical connection (by others) of truss to bearing plate capable of withstanding 88 lb uplift at joint 8 and 102 lb uplift at joint 9.

LOAD CASE(S) Standard



October 3, 2025

WARNING - Verify design parameters and READ NOTES ON THIS AND INCLUDED MITEK REFERENCE PAGE MII-7473 rev. 1/2/2023 BEFORE USE.

Design valid for use only with MiTek® connectors. This design is based only upon parameters shown, and is for an individual building component, not a truss system. Before use, the building designer must verify the applicability of design parameters and properly incorporate this design into the overall building design. Bracing indicated is to prevent buckling of individual truss web and/or chord members only. Additional temporary and permanent bracing is always required for stability and to prevent collapse with possible personal injury and property damage. For general guidance regarding the fabrication, storage, delivery, erection and bracing of trusses and truss systems, see **ANSI/TPI1 Quality Criteria and DSB-22** available from Truss Plate Institute (www.tpinst.org) and **BCSI Building Component Safety Information** available from the Structural Building Component Association (www.sbcsccomponents.com)

MiTek®

400 Sunrise Ave., Suite 270
Roseville, CA 95661
916.755.3571 / MiTek-US.com

Job J1183948	Truss A03	Truss Type Roof Special	Qty 8	Ply 1	NW Eastside Builders LLC Job Reference (optional)	R90572881
-----------------	--------------	----------------------------	----------	----------	--	-----------

The Truss Company (Sumner, WA), Sumner, WA - 98390,

Run: 25.30 S Sep 17 2025 Print: 25.30 S Sep 17 2025 MiTek Industries, Inc. Thu Oct 02 17:24:47
ID:LiqgYy6JCxEUT?b4VWT4jz9C3k-RfC?PsB70Hq3NSgPqnL8w3uITxbGKWrCDoi7J4zJC?f

Page: 1

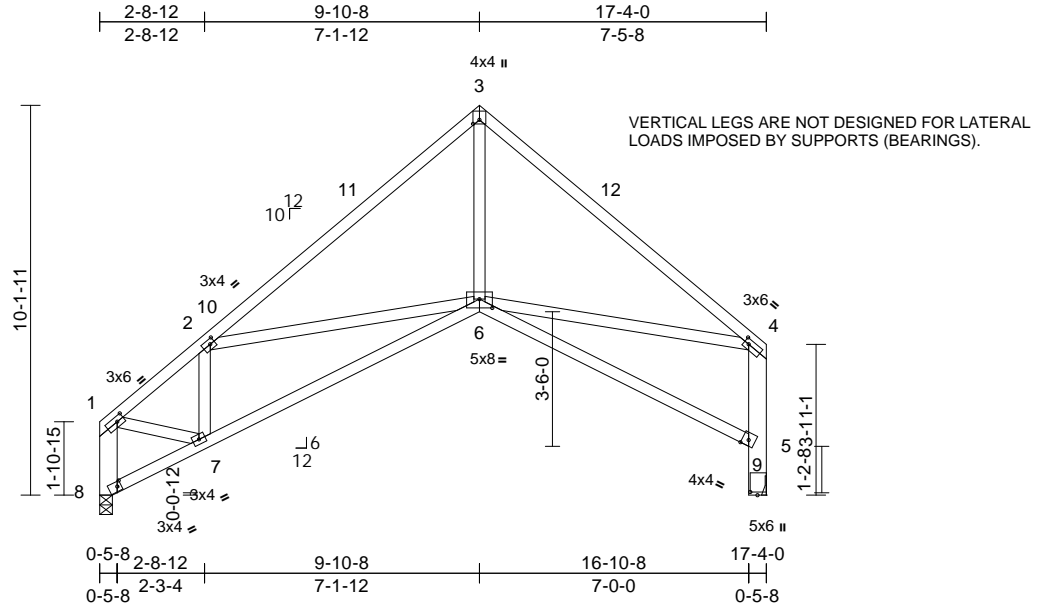

Scale = 1:59.9

Plate Offsets (X, Y): [1:0-2-4,0-1-8], [2:0-1-8,0-1-8], [3:0-1-4,0-2-0], [4:0-1-8,0-1-8], [6:0-4-0,0-2-12], [8:0-1-4,0-1-8], [9:0-1-0,0-2-4]

Loading	(psf)	Spacing	2-0-0	CSI	DEFL	in	(loc)	l/defl	L/d	PLATES	GRIP	
TCLL (Roof Snow = 25.0)	25.0	Plate Grip DOL	1.15	TC	0.67	Vert(LL)	-0.09	5-6	>999	240	MT20	185/148
TCDL	8.0	Lumber DOL	1.15	BC	0.29	Vert(CT)	-0.16	5-6	>999	180		
BCLL	0.0*	Rep Stress Incr	YES	WB	0.23	Horz(CT)	0.06	9	n/a	n/a		
BCDL	7.0	Code	IRC2021/TPI2014	Matrix-MS								
											Weight: 96 lb	FT = 20%

LUMBER

TOP CHORD 2x4 HF-N No.1/No.2
 BOT CHORD 2x4 HF-N No.1/No.2
 WEBS 2x4 DF Stud *Except* 8-1,9-4:2x6 DF SS

BRACING

TOP CHORD Structural wood sheathing directly applied or 3-11-6 oc purlins, except end verticals.
 BOT CHORD Rigid ceiling directly applied or 6-0-0 oc bracing.

REACTIONS

(size) 8=0-4-0, 9= Mechanical
 Max Horiz 8=200 (LC 9)
 Max Uplift 8=-88 (LC 10), 9=-101 (LC 10)
 Max Grav 8=675 (LC 1), 9=675 (LC 1)

FORCES

(lb) - Maximum Compression/Maximum Tension
 TOP CHORD 1-2=-852/156, 2-3=-937/120, 3-4=-932/118,
 1-8=-669/101, 5-9=-675/101, 4-5=-667/141
 BOT CHORD 7-8=-228/203, 6-7=-262/887, 5-6=-91/143
 WEBS 3-6=-37/572, 2-7=-404/160, 1-7=-143/703,
 2-6=-177/256, 4-6=-62/542

NOTES

- 1) Wind: ASCE 7-16; Vult=110mph (3-second gust)
 Vasd=87mph; TCDL=4.8psf; BCDL=4.2psf; h=25ft; Cat. II; Exp B; Partially Enclosed; MWFRS (envelope) exterior zone and C-C Exterior(2E) 0-2-12 to 3-2-12, Interior (1) 3-2-12 to 6-10-8, Exterior(2R) 6-10-8 to 12-10-8, Interior (1) 12-10-8 to 17-1-4 zone; cantilever left and right exposed; end vertical left and right exposed; C-C for members and forces & MWFRS for reactions shown; Lumber DOL=1.60 plate grip DOL=1.60
- 2) TCLL: ASCE 7-16; Pf=25.0 psf (Lum DOL = 1.15 Plate DOL = 1.15); Is=1.0; Rough Cat B; Partially Exp.; Ce=1.0; Cs=1.00; Ct=1.10
- 3) This truss has been designed for a 10.0 psf bottom chord live load nonconcurrent with any other live loads.

- 4) * This truss has been designed for a live load of 20.0psf on the bottom chord in all areas where a rectangle 3-06-00 tall by 2-00-00 wide will fit between the bottom chord and any other members.
 - 5) Refer to girder(s) for truss to truss connections.
 - 6) Bearing at joint(s) 8 considers parallel to grain value using ANSI/TPI 1 angle to grain formula. Building designer should verify capacity of bearing surface.
 - 7) Provide mechanical connection (by others) of truss to bearing plate capable of withstanding 88 lb uplift at joint 8 and 101 lb uplift at joint 9.
- LOAD CASE(S)** Standard



October 3, 2025

WARNING - Verify design parameters and READ NOTES ON THIS AND INCLUDED MITEK REFERENCE PAGE MII-7473 rev. 1/2/2023 BEFORE USE.

Design valid for use only with MiTek® connectors. This design is based only upon parameters shown, and is for an individual building component, not a truss system. Before use, the building designer must verify the applicability of design parameters and properly incorporate this design into the overall building design. Bracing indicated is to prevent buckling of individual truss web and/or chord members only. Additional temporary and permanent bracing is always required for stability and to prevent collapse with possible personal injury and property damage. For general guidance regarding the fabrication, storage, delivery, erection and bracing of trusses and truss systems, see **ANSI/TPI1 Quality Criteria and DSB-22** available from Truss Plate Institute (www.tpinst.org) and **BCSI Building Component Safety Information** available from the Structural Building Component Association (www.sbcsccomponents.com)

MiTek®

400 Sunrise Ave., Suite 270
 Roseville, CA 95661
 916.755.3571 / MiTek-US.com

Job J1183948	Truss A04	Truss Type Common Girder	Qty 1	Ply 2	NW Eastside Builders LLC Job Reference (optional)	R90572882
-----------------	--------------	-----------------------------	----------	----------	--	-----------

The Truss Company (Sumner, WA), Sumner, WA - 98390,

Run: 25.30 S Sep 17 2025 Print: 25.3.0 S Sep 17 2025 MiTek Industries, Inc. Thu Oct 02 17:24:47
ID:piWLYfuCqKENUdf0kG3xCz9U_X-RfC?PsB70Hq3NSgPqnL8w3uITxBGKWrCDoi7J4zJC7f

Page: 1

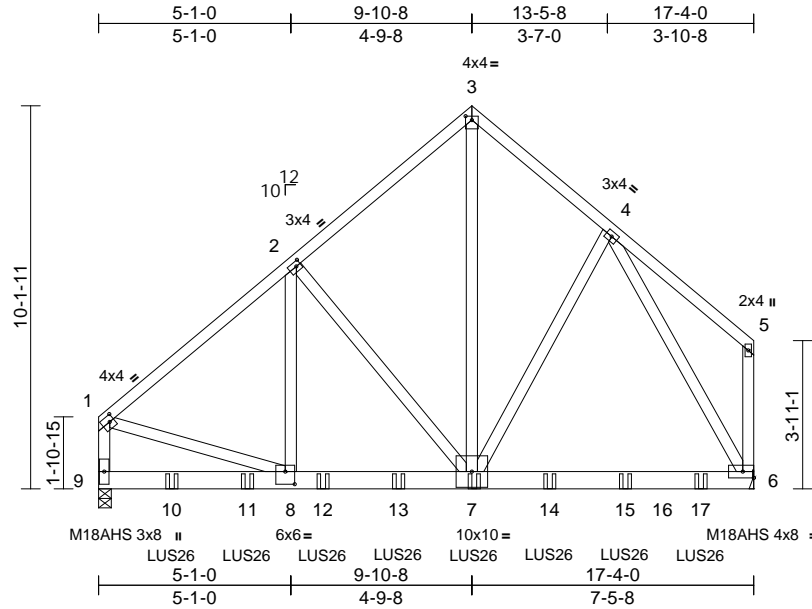

Scale = 1:61

Plate Offsets (X, Y): [1:0-1-8,0-2-0], [2:0-1-8,0-1-8], [3:0-2-0,0-1-4], [8:0-3-0,0-4-0]

Loading	(psf)	Spacing	2-0-0	CSI	DEFL	in	(loc)	l/defl	L/d	PLATES	GRIP	
TCLL	25.0	Plate Grip DOL	1.15	TC	0.79	Vert(LL)	-0.16	6-7	>999	240	MT20	185/148
(Roof Snow = 25.0)		Lumber DOL	1.15	BC	0.81	Vert(CT)	-0.24	6-7	>843	180	M18AHS	169/162
TCDL	8.0	Rep Stress Incr	NO	WB	0.64	Horz(CT)	0.01	6	n/a	n/a		
BCLL	0.0*	Code	IRC2021/TPI2014	Matrix-MS								
BCDL	7.0											
											Weight: 248 lb	FT = 20%

LUMBER

TOP CHORD 2x4 HF-N No.1/No.2
BOT CHORD 2x6 DF SS
WEBS 2x4 DF Stud *Except* 7-2,7-3,7-4,6-4:2x4 HF-N No.1/No.2

BRACING

TOP CHORD Structural wood sheathing directly applied or 6-0-0 oc purlins, except end verticals.
BOT CHORD Rigid ceiling directly applied or 10-0-0 oc bracing.

REACTIONS

(size) 6= Mechanical, 9=0-4-0
Max Horiz 9=194 (LC 7)
Max Uplift 6=-861 (LC 8), 9=-804 (LC 8)
Max Grav 6=4614 (LC 15), 9=4359 (LC 16)

FORCES

(lb) - Maximum Compression/Maximum Tension

TOP CHORD 1-2=-4027/771, 2-3=-3078/666,
3-4=-3026/683, 4-5=-325/137,
1-9=-3568/677, 5-6=-301/106
BOT CHORD 8-9=-223/358, 7-8=-600/3092, 6-7=-308/1747
WEBS 2-8=-240/1238, 2-7=-1249/365,
3-7=-765/3561, 4-7=-222/1133,
1-8=-494/2939, 4-6=-3353/592

NOTES

- 2-ply truss to be connected together with 10d (0.131"x3") nails as follows:
Top chords connected as follows: 2x4 - 1 row at 0-9-0 oc.
Bottom chords connected as follows: 2x6 - 2 rows staggered at 0-9-0 oc.
Web connected as follows: 2x4 - 1 row at 0-9-0 oc.
- All loads are considered equally applied to all plies, except if noted as front (F) or back (B) face in the LOAD CASE(S) section. Ply to ply connections have been provided to distribute only loads noted as (F) or (B), unless otherwise indicated.

- Wind: ASCE 7-16; Vult=110mph (3-second gust)
Vasd=87mph; TCDL=4.8psf; BCDL=4.2psf; h=25ft; Cat. II; Exp B; Partially Enclosed; MWFRS (envelope) exterior zone; cantilever left and right exposed; end vertical left and right exposed; Lumber DOL=1.60 plate grip DOL=1.60
- TCLL: ASCE 7-16; Pf=25.0 psf (Lum DOL = 1.15 Plate DOL = 1.15); Is=1.0; Rough Cat B; Partially Exp.; Ce=1.0; Cs=1.00; Ct=1.10
- All plates are MT20 plates unless otherwise indicated.
- This truss has been designed for a 10.0 psf bottom chord live load nonconcurrent with any other live loads.
- * This truss has been designed for a live load of 20.0psf on the bottom chord in all areas where a rectangle 3-06-00 tall by 2-00-00 wide will fit between the bottom chord and any other members, with BCDL = 7.0psf.
- Refer to girder(s) for truss to truss connections.
- Provide mechanical connection (by others) of truss to bearing plate capable of withstanding 804 lb uplift at joint 9 and 861 lb uplift at joint 6.
- Use Simpson Strong-Tie LUS26 (4-10d Girder, 4-10d Truss) or equivalent spaced at 2-0-0 oc max. starting at 1-11-4 from the left end to 15-11-4 to connect truss(es) to back face of bottom chord.
- Fill all nail holes where hanger is in contact with lumber.

LOAD CASE(S) Standard

- Dead + Snow (balanced): Lumber Increase=1.15, Plate Increase=1.15
Uniform Loads (lb/ft)
Vert: 1-3=-66, 3-5=-66, 6-9=-14
Concentrated Loads (lb)
Vert: 7=-836 (B), 10=-836 (B), 11=-836 (B), 12=-836 (B), 13=-836 (B), 14=-836 (B), 15=-836 (B), 17=-836 (B)



October 3, 2025

WARNING - Verify design parameters and READ NOTES ON THIS AND INCLUDED MITEK REFERENCE PAGE MII-7473 rev. 1/2/2023 BEFORE USE.

Design valid for use only with MiTek® connectors. This design is based only upon parameters shown, and is for an individual building component, not a truss system. Before use, the building designer must verify the applicability of design parameters and properly incorporate this design into the overall building design. Bracing indicated is to prevent buckling of individual truss web and/or chord members only. Additional temporary and permanent bracing is always required for stability and to prevent collapse with possible personal injury and property damage. For general guidance regarding the fabrication, storage, delivery, erection and bracing of trusses and truss systems, see **ANSI/TPI1 Quality Criteria and DSB-22** available from Truss Plate Institute (www.tpinst.org) and **BCSI Building Component Safety Information** available from the Structural Building Component Association (www.sbcsccomponents.com)

MiTek®

400 Sunrise Ave., Suite 270
Roseville, CA 95661
916.755.3571 / MiTek-US.com

Job J1183948	Truss A05	Truss Type Scissor Supported Gable	Qty 1	Ply 1	NW Eastside Builders LLC Job Reference (optional)	R90572883
-----------------	--------------	---------------------------------------	----------	----------	--	-----------

The Truss Company (Sumner, WA), Sumner, WA - 98390,

Run: 25.30 S Sep 17 2025 Print: 25.3.0 S Sep 17 2025 MiTek Industries, Inc. Thu Oct 02 17:24:47
ID:t87AmQZhbv?O2VissXAYtXz980x-RfC?Psb70Hq3NSgPqnL8w3uITXbGKWrCdoi7J4zJC?F

Page: 1

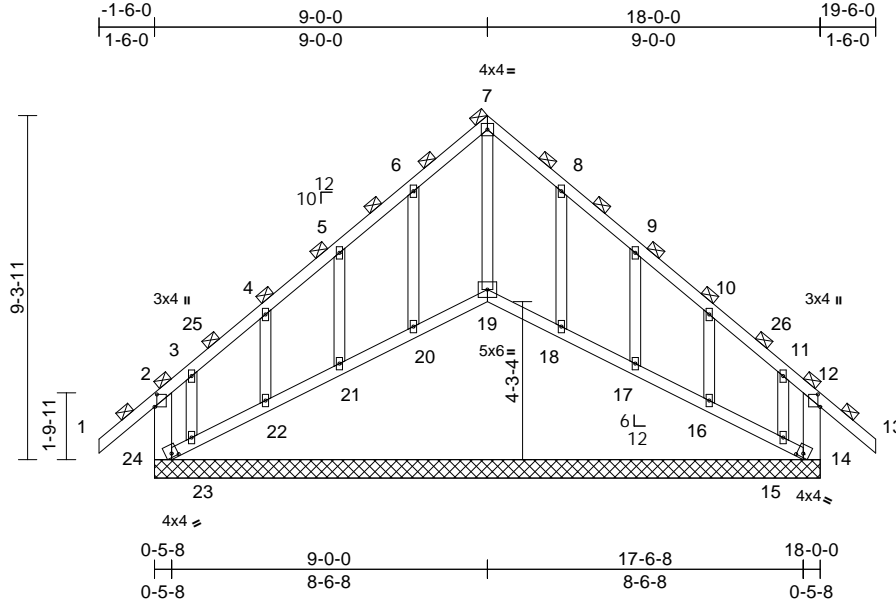

Scale = 1:62.3

Plate Offsets (X, Y): [2:0-4-1,0-0-12], [12:0-4-1,0-0-12], [14:0-2-0,0-1-3], [24:0-2-0,0-1-3]

Loading	(psf)	Spacing	2-6-0	CSI	DEFL	in	(loc)	l/defl	L/d	PLATES	GRIP	
TCLL (Roof Snow = 25.0)	25.0	Plate Grip DOL	1.15	TC	0.26	Vert(LL)	n/a	-	n/a	999	MT20	185/148
TCDL	8.0	Lumber DOL	1.15	BC	0.14	Vert(CT)	n/a	-	n/a	999		
BCLL	0.0*	Rep Stress Incr	NO	WB	0.18	Horz(CT)	-0.01	14	n/a	n/a		
BCDL	7.0	Code	IRC2021/TPI2014	Matrix-MR								
											Weight: 103 lb	FT = 20%

LUMBER		
TOP CHORD	2x4 HF-N No.1/No.2	
BOT CHORD	2x4 HF-N No.1/No.2	
WEBS	2x6 DF SS	
OTHERS	2x4 DF Stud	
BRACING		
TOP CHORD	2-0-0 oc purlins (10-0-0 max.), except end verticals (Switched from sheeted: Spacing > 2-0-0).	
BOT CHORD	Rigid ceiling directly applied or 6-0-0 oc bracing.	
REACTIONS	(size)	
	14=18-0-0, 15=18-0-0, 16=18-0-0, 17=18-0-0, 18=18-0-0, 19=18-0-0, 20=18-0-0, 21=18-0-0, 22=18-0-0, 23=18-0-0, 24=18-0-0	
Max Horiz	24=238 (LC 8)	
Max Uplift	14=200 (LC 7), 15=298 (LC 6), 16=92 (LC 11), 17=104 (LC 11), 18=94 (LC 11), 19=175 (LC 9), 20=95 (LC 10), 21=104 (LC 10), 22=92 (LC 10), 23=338 (LC 7), 24=352 (LC 6)	
Max Grav	14=318 (LC 18), 15=345 (LC 9), 16=224 (LC 19), 17=221 (LC 19), 18=236 (LC 19), 19=441 (LC 11), 20=237 (LC 18), 21=221 (LC 18), 22=222 (LC 18), 23=390 (LC 8), 24=443 (LC 19)	
FORCES	(lb) - Maximum Compression/Maximum Tension	
TOP CHORD	2-24=287/186, 1-2=0/91, 2-3=192/199, 3-4=114/139, 4-5=123/230, 5-6=150/332, 6-7=211/427, 7-8=211/427, 8-9=150/332, 9-10=101/230, 10-11=93/127, 11-12=155/166, 12-13=0/91, 12-14=258/152	

BOT CHORD	
23-24=209/193, 22-23=158/180, 21-22=164/179, 20-21=163/179, 19-20=164/179, 18-19=164/179, 17-18=163/180, 16-17=162/179, 15-16=166/182, 14-15=103/139	
WEBS	
7-19=465/160, 6-20=200/125, 5-21=185/136, 4-22=194/139, 3-23=213/205, 8-18=199/125, 9-17=185/136, 10-16=195/136, 11-15=189/183	

NOTES

- 1) Wind: ASCE 7-16; Vult=110mph (3-second gust) Vasd=87mph; TCDL=4.8psf; BCDL=4.2psf; h=25ft; Cat. II; Exp B; Partially Enclosed; MWFRS (envelope) exterior zone and C-C Corner(3E) -1-6-0 to 1-6-0, Exterior(2N) 1-6-0 to 6-0-0, Corner(3R) 6-0-0 to 12-0-0, Exterior(2N) 12-0-0 to 16-6-0, Corner(3E) 16-6-0 to 19-6-0 zone; cantilever left and right exposed; and vertical left and right exposed; C-C for members and forces & MWFRS for reactions shown; Lumber DOL=1.60 plate grip DOL=1.60
- 2) Truss designed for wind loads in the plane of the truss only. For studs exposed to wind (normal to the face), see Standard Industry Gable End Details as applicable, or consult qualified building designer as per ANSI/TPI 1.
- 3) TCLL: ASCE 7-16; Pf=25.0 psf (Lum DOL = 1.15 Plate DOL = 1.15); Is=1.0; Rough Cat B; Partially Exp.; Ce=1.0; Cs=1.00; Ct=1.10
- 4) This truss has been designed for greater of min roof live load of 16.0 psf or 1.00 times flat roof load of 25.0 psf on overhangs non-concurrent with other live loads.
- 5) All plates are 2x4 (||) MT20 unless otherwise indicated.
- 6) Gable requires continuous bottom chord bearing.
- 7) Truss to be fully sheathed from one face or securely braced against lateral movement (i.e. diagonal web).
- 8) Gable studs spaced at 2-0-0 oc.
- 9) This truss has been designed for a 10.0 psf bottom chord live load nonconcurrent with any other live loads.

- 10) * This truss has been designed for a live load of 20.0psf on the bottom chord in all areas where a rectangle 3-06-00 tall by 2-00-00 wide will fit between the bottom chord and any other members.
- 11) Bearing at joint(s) 24, 14 considers parallel to grain value using ANSI/TPI 1 angle to grain formula. Building designer should verify capacity of bearing surface.
- 12) Provide mechanical connection (by others) of truss to bearing plate capable of withstanding 175 lb uplift at joint 19, 352 lb uplift at joint 24, 200 lb uplift at joint 14, 95 lb uplift at joint 20, 104 lb uplift at joint 21, 92 lb uplift at joint 22, 338 lb uplift at joint 23, 94 lb uplift at joint 18, 104 lb uplift at joint 17, 92 lb uplift at joint 16 and 298 lb uplift at joint 15.
- 13) Beveled plate or shim required to provide full bearing surface with truss chord at joint(s) 19, 20, 21, 22, 23, 18, 17, 16, 15.
- 14) Graphical purlin representation does not depict the size or the orientation of the purlin along the top and/or bottom chord.

LOAD CASE(S) Standard



October 3, 2025

WARNING - Verify design parameters and READ NOTES ON THIS AND INCLUDED MITEK REFERENCE PAGE MII-7473 rev. 1/2023 BEFORE USE.

Design valid for use only with MiTek® connectors. This design is based only upon parameters shown, and is for an individual building component, not a truss system. Before use, the building designer must verify the applicability of design parameters and properly incorporate this design into the overall building design. Bracing indicated is to prevent buckling of individual truss web and/or chord members only. Additional temporary and permanent bracing is always required for stability and to prevent collapse with possible personal injury and property damage. For general guidance regarding the fabrication, storage, delivery, erection and bracing of trusses and truss systems, see **ANSI/TPI1 Quality Criteria and DSB-22** available from Truss Plate Institute (www.tpinst.org) and **BCSI Building Component Safety Information** available from the Structural Building Component Association (www.sbcsccomponents.com)

MiTek®

400 Sunrise Ave., Suite 270
Roseville, CA 95661
916.755.3571 / MiTek-US.com

Job J1183948	Truss A06	Truss Type Scissor	Qty 1	Ply 1	NW Eastside Builders LLC Job Reference (optional)	R90572884
-----------------	--------------	-----------------------	----------	----------	--	-----------

The Truss Company (Sumner, WA), Sumner, WA - 98390,

Run: 25.30 S Sep 17 2025 Print: 25.3.0 S Sep 17 2025 MiTek Industries, Inc. Thu Oct 02 17:24:48
ID:B2U6ND?g8VnV_moQKzT0F2z9Cgc-RfC?PsB70Hq3NSgPqnL8w3uTXbGKWrCDoi7J4zJC?f

Page: 1

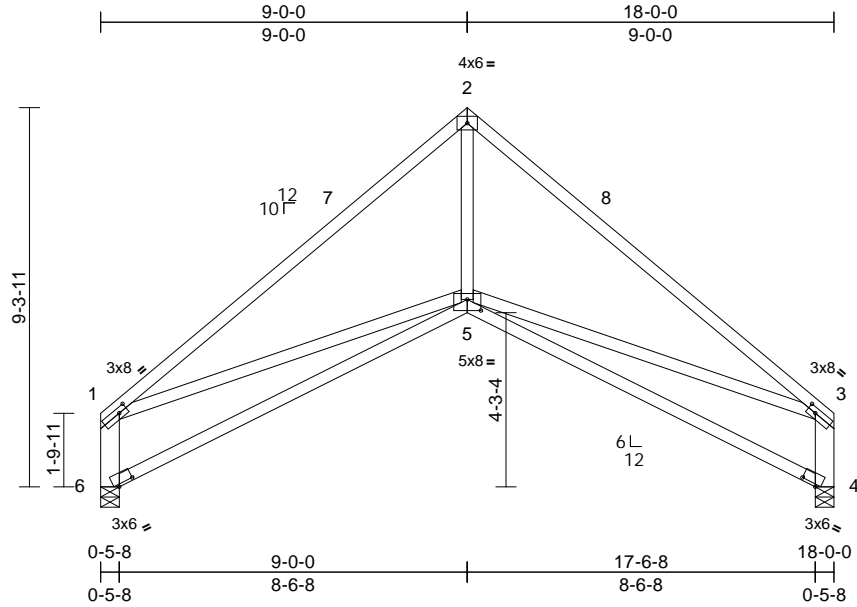

Scale = 1:56.5

Plate Offsets (X, Y): [1:0-2-8,0-1-8], [3:0-2-8,0-1-8], [4:0-4-10,0-0-12], [5:0-4-0,0-3-4], [6:0-4-10,0-0-12]

Loading	(psf)	Spacing	2-0-0	CSI	DEFL	in	(loc)	l/defl	L/d	PLATES	GRIP	
TCLL (Roof Snow = 25.0)	25.0	Plate Grip DOL	1.15	TC	0.63	Vert(LL)	-0.18	4-5	>999	240	MT20	220/195
TCDL	8.0	Lumber DOL	1.15	BC	0.40	Vert(CT)	-0.32	4-5	>662	180		
BCLL	0.0*	Rep Stress Incr	YES	WB	0.21	Horz(CT)	0.06	4	n/a	n/a		
BCDL	7.0	Code	IRC2021/TPI2014	Matrix-MS								
											Weight: 93 lb	FT = 20%

LUMBER

TOP CHORD 2x4 DF 2400F 2.0E
 BOT CHORD 2x4 HF-N No.1/No.2
 WEBS 2x6 DF SS *Except* 5-2:2x4 DF Stud,
 5-1,5-3:2x4 HF-N No.1/No.2

BRACING

TOP CHORD Structural wood sheathing directly applied or
 5-4-1 oc purlins, except end verticals.
 BOT CHORD Rigid ceiling directly applied or 10-0-0 oc
 bracing.

REACTIONS

(size) 4=0-5-8, 6=0-5-8
 Max Horiz 6=-166 (LC 8)
 Max Uplift 4=-92 (LC 11), 6=-92 (LC 10)
 Max Grav 4=702 (LC 1), 6=702 (LC 1)

FORCES

(lb) - Maximum Compression/Maximum
 Tension
 TOP CHORD 1-2=-1133/85, 2-3=-1133/132, 1-6=-748/200,
 3-4=-735/178
 BOT CHORD 5-6=-241/391, 4-5=-126/252
 WEBS 2-5=0/655, 1-5=0/560, 3-5=-54/600

NOTES

- 1) Wind: ASCE 7-16; Vult=110mph (3-second gust)
 Vasd=87mph; TCCL=4.8psf; BCDL=4.2psf; h=25ft; Cat.
 II; Exp B; Partially Enclosed; MWFRS (envelope)
 exterior zone and C-C Exterior(2E) 0-2-12 to 3-2-12,
 Interior (1) 3-2-12 to 6-0-0, Exterior(2R) 6-0-0 to 12-0-0,
 Interior (1) 12-0-0 to 14-9-4, Exterior(2E) 14-9-4 to
 17-9-4 zone; cantilever left and right exposed ; end
 vertical left and right exposed;C-C for members and
 forces & MWFRS for reactions shown; Lumber
 DOL=1.60 plate grip DOL=1.60
- 2) TCLL: ASCE 7-16; Pf=25.0 psf (Lum DOL = 1.15 Plate
 DOL = 1.15); Is=1.0; Rough Cat B; Partially Exp. ;
 Ce=1.0; Cs=1.00; Ct=1.10
- 3) This truss has been designed for a 10.0 psf bottom
 chord live load nonconcurrent with any other live loads.

- 4) * This truss has been designed for a live load of 20.0psf
 on the bottom chord in all areas where a rectangle
 3-06-00 tall by 2-00-00 wide will fit between the bottom
 chord and any other members.
- 5) Bearing at joint(s) 6, 4 considers parallel to grain value
 using ANSI/TPI 1 angle to grain formula. Building
 designer should verify capacity of bearing surface.
- 6) Provide mechanical connection (by others) of truss to
 bearing plate capable of withstanding 92 lb uplift at joint
 6 and 92 lb uplift at joint 4.

LOAD CASE(S) Standard



October 3, 2025

WARNING - Verify design parameters and READ NOTES ON THIS AND INCLUDED MITEK REFERENCE PAGE MII-7473 rev. 1/2/2023 BEFORE USE.

Design valid for use only with MiTek® connectors. This design is based only upon parameters shown, and is for an individual building component, not a truss system. Before use, the building designer must verify the applicability of design parameters and properly incorporate this design into the overall building design. Bracing indicated is to prevent buckling of individual truss web and/or chord members only. Additional temporary and permanent bracing is always required for stability and to prevent collapse with possible personal injury and property damage. For general guidance regarding the fabrication, storage, delivery, erection and bracing of trusses and truss systems, see **ANSI/TPI1 Quality Criteria and DSB-22** available from Truss Plate Institute (www.tpinst.org) and **BCSI Building Component Safety Information** available from the Structural Building Component Association (www.sbcsccomponents.com)

MiTek®

400 Sunrise Ave., Suite 270
 Roseville, CA 95661
 916.755.3571 / MiTek-US.com

Job J1183948	Truss A07	Truss Type Scissor	Qty 7	Ply 1	NW Eastside Builders LLC Job Reference (optional)	R90572885
-----------------	--------------	-----------------------	----------	----------	--	-----------

The Truss Company (Sumner, WA), Sumner, WA - 98390,

Run: 25.30 S Sep 17 2025 Print: 25.3.0 S Sep 17 2025 MiTek Industries, Inc. Thu Oct 02 17:24:48
ID:4oZs6NMLMOz3arQj4YQTi8z9C6?-RfC?PsB70Hq3NSgPqnL8w3ulTXbGKWRcDoi7J4zJC?l

Page: 1

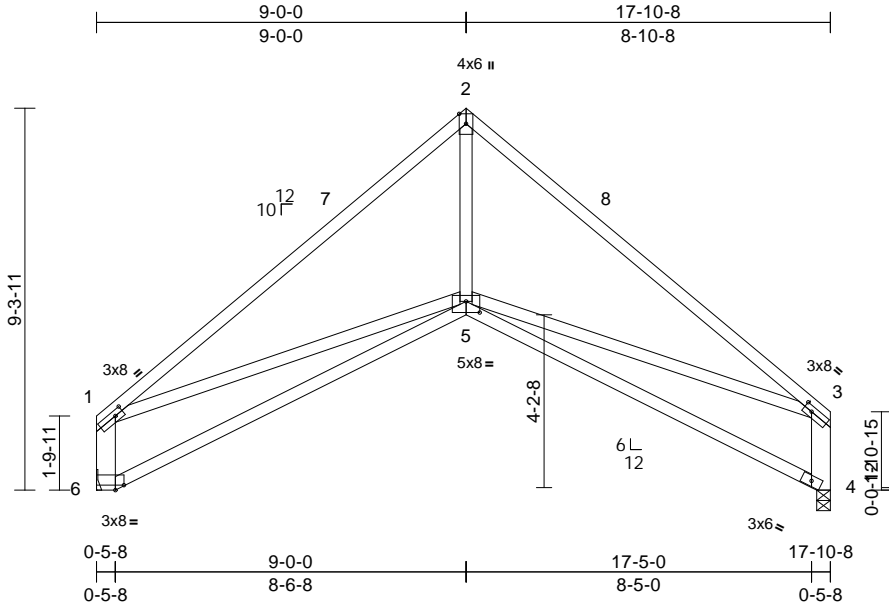

Scale = 1:56.1

Plate Offsets (X, Y): [1:0-2-8,0-1-8], [3:0-2-8,0-1-8], [5:0-4-0,0-3-4], [6:0-2-8,0-1-7]

Loading	(psf)	Spacing	2-0-0	CSI	DEFL	in	(loc)	l/defl	L/d	PLATES	GRIP	
TCLL	25.0	Plate Grip DOL	1.15	TC	0.88	Vert(LL)	-0.19	5-6	>999	240	MT20	220/195
(Roof Snow = 25.0)		Lumber DOL	1.15	BC	0.41	Vert(CT)	-0.32	5-6	>641	180		
TCDL	8.0	Rep Stress Incr	YES	WB	0.20	Horz(CT)	0.06	4	n/a	n/a		
BCLL	0.0*	Code	IRC2021/TPI2014	Matrix-MS								
BCDL	7.0											
											Weight: 92 lb	FT = 20%

LUMBER	
TOP CHORD	2x4 DF 2400F 2.0E *Except* 2-3:2x4 DF 1800F 1.6E or 2x4 DF No.1&Btr or 2x4 DF-N 1800F 1.6E
BOT CHORD	2x4 HF-N No.1/No.2
WEBS	2x6 DF SS *Except* 5-2:2x4 DF Stud, 5-1,5-3:2x4 HF-N No.1/No.2
BRACING	
TOP CHORD	Structural wood sheathing directly applied, except end verticals.
BOT CHORD	Rigid ceiling directly applied or 10-0-0 oc bracing.
REACTIONS	
(size)	4=0-4-0, 6= Mechanical
Max Horiz	6=167 (LC 7)
Max Uplift	4=-94 (LC 11), 6=-91 (LC 10)
Max Grav	4=701 (LC 1), 6=690 (LC 1)
FORCES	
(lb) - Maximum Compression/Maximum Tension	
TOP CHORD	1-2=-1103/82, 2-3=-1100/130, 1-6=-738/200, 3-4=-686/161
BOT CHORD	5-6=-243/393, 4-5=-104/172
WEBS	2-5=0/622, 1-5=0/535, 3-5=-51/645

- This truss has been designed for a 10.0 psf bottom chord live load nonconcurrent with any other live loads.
- * This truss has been designed for a live load of 20.0psf on the bottom chord in all areas where a rectangle 3-06-00 tall by 2-00-00 wide will fit between the bottom chord and any other members.
- Refer to girder(s) for truss to truss connections.
- Bearing at joint(s) 4 considers parallel to grain value using ANSI/TPI 1 angle to grain formula. Building designer should verify capacity of bearing surface.
- Provide mechanical connection (by others) of truss to bearing plate capable of withstanding 91 lb uplift at joint 6 and 94 lb uplift at joint 4.

LOAD CASE(S) Standard

- NOTES**
- Wind: ASCE 7-16; Vult=110mph (3-second gust) Vasd=87mph; TCCL=4.8psf; BCCL=4.2psf; h=25ft; Cat. II; Exp B; Partially Enclosed; MWFRS (envelope) exterior zone and C-C Exterior(2E) 0-2-12 to 3-2-12, Interior (1) 3-2-12 to 6-0-0, Exterior(2R) 6-0-0 to 12-0-0, Interior (1) 12-0-0 to 14-7-12, Exterior(2E) 14-7-12 to 17-7-12 zone; cantilever left and right exposed; end vertical left and right exposed; C-C for members and forces & MWFRS for reactions shown; Lumber DOL=1.60 plate grip DOL=1.60
 - TCLL: ASCE 7-16; Pf=25.0 psf (Lum DOL = 1.15 Plate DOL = 1.15); Is=1.0; Rough Cat B; Partially Exp.; Ce=1.0; Cs=1.00; Ct=1.10



October 3, 2025

WARNING - Verify design parameters and READ NOTES ON THIS AND INCLUDED MITEK REFERENCE PAGE MII-7473 rev. 1/2/2023 BEFORE USE.

Design valid for use only with MiTek® connectors. This design is based only upon parameters shown, and is for an individual building component, not a truss system. Before use, the building designer must verify the applicability of design parameters and properly incorporate this design into the overall building design. Bracing indicated is to prevent buckling of individual truss web and/or chord members only. Additional temporary and permanent bracing is always required for stability and to prevent collapse with possible personal injury and property damage. For general guidance regarding the fabrication, storage, delivery, erection and bracing of trusses and truss systems, see **ANSI/TPI1 Quality Criteria and DSB-22** available from Truss Plate Institute (www.tpinst.org) and **BCSI Building Component Safety Information** available from the Structural Building Component Association (www.sbcsccomponents.com)

MiTek®

400 Sunrise Ave., Suite 270
Roseville, CA 95661
916.755.3571 / MiTek-US.com

Job J1183948	Truss A08	Truss Type Common Girder	Qty 1	Ply 2	NW Eastside Builders LLC Job Reference (optional)	R90572886
-----------------	--------------	-----------------------------	----------	----------	--	-----------

The Truss Company (Sumner, WA), Sumner, WA - 98390,

Run: 25.30 S Sep 17 2025 Print: 25.30 S Sep 17 2025 MiTek Industries, Inc. Thu Oct 02 17:24:48
ID:iviTr?L5RJ87F6CygSDTKsz98SK-RFC?PsB70Hq3NSgPqnL8w3uITXbGKWRcDoi7J4zJC?f

Page: 1

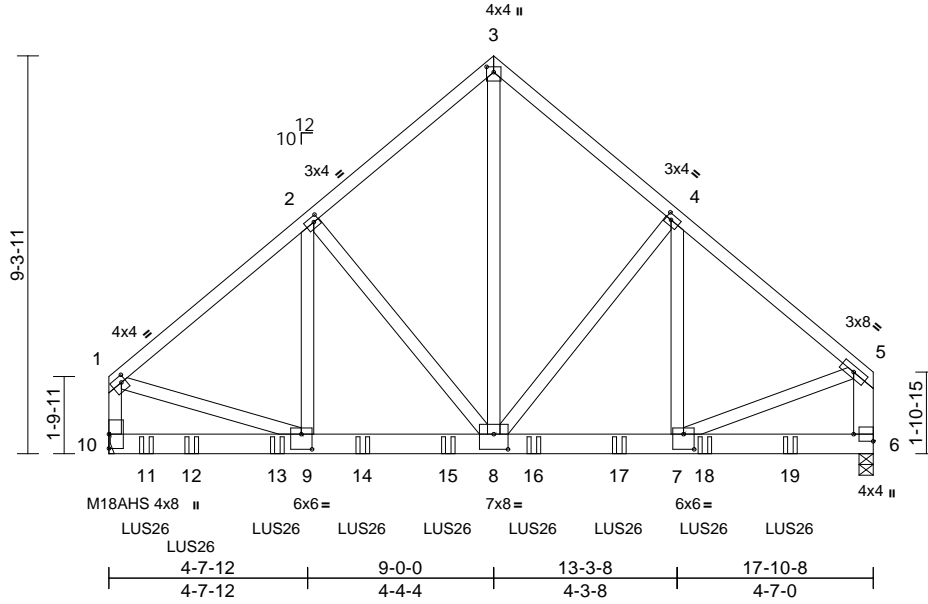

Scale = 1:53.9

Plate Offsets (X, Y): [1:0-1-4,0-1-12], [2:0-1-8,0-1-8], [3:0-1-8,0-2-0], [4:0-1-8,0-1-8], [6:Edge,0-5-8], [7:0-3-0,0-4-4], [8:0-4-0,0-4-4], [9:0-3-0,0-4-4]

Loading	(psf)	Spacing	2-0-0	CSI	DEFL	in	(loc)	l/defl	L/d	PLATES	GRIP	
TCLL	25.0	Plate Grip DOL	1.15	TC	0.35	Vert(LL)	-0.05	7-8	>999	240	MT20	185/148
(Roof Snow = 25.0)		Lumber DOL	1.15	BC	0.39	Vert(CT)	-0.08	7-8	>999	180	M18AHS	145/140
TCDL	8.0	Rep Stress Incr	NO	WB	0.53	Horz(CT)	0.01	6	n/a	n/a		
BCLL	0.0*	Code	IRC2021/TPI2014	Matrix-MS								
BCDL	7.0											
											Weight: 251 lb	FT = 20%

LUMBER

TOP CHORD 2x4 HF-N No.1/No.2
 BOT CHORD 2x6 DF SS
 WEBS 2x4 DF Stud *Except* 10-1,8-3:2x4 HF-N No.1/No.2, 6-5:2x6 DF SS

BRACING

TOP CHORD Structural wood sheathing directly applied or 6-0-0 oc purlins, except end verticals.
 BOT CHORD Rigid ceiling directly applied or 10-0-0 oc bracing.

REACTIONS

(size) 6=0-4-0, 10= Mechanical
 Max Horiz 10=163 (LC 22)
 Max Uplift 6=-830 (LC 9), 10=-990 (LC 8)
 Max Grav 6=5499 (LC 15), 10=5459 (LC 16)

FORCES

(lb) - Maximum Compression/Maximum Tension
 TOP CHORD 1-2=-4508/847, 2-3=-3409/719, 3-4=-3407/720, 4-5=-4239/801, 1-10=-4004/739, 5-6=-3904/721
 BOT CHORD 9-10=-201/402, 8-9=-627/3463, 7-8=-537/3194, 6-7=-69/297
 WEBS 1-9=-553/3282, 5-7=-524/3105, 2-9=-277/1509, 2-8=-1414/373, 3-8=-820/3994, 4-8=-1108/315, 4-7=-213/1119

NOTES

- 2-ply truss to be connected together with 10d (0.131"x3") nails as follows:
 Top chords connected as follows: 2x4 - 1 row at 0-9-0 oc, 2x6 - 2 rows staggered at 0-9-0 oc.
 Bottom chords connected as follows: 2x6 - 2 rows staggered at 0-7-0 oc.
 Web connected as follows: 2x4 - 1 row at 0-9-0 oc.

- All loads are considered equally applied to all plies, except if noted as front (F) or back (B) face in the LOAD CASE(S) section. Ply to ply connections have been provided to distribute only loads noted as (F) or (B), unless otherwise indicated.
- Wind: ASCE 7-16; Vult=110mph (3-second gust) Vasd=87mph; TC DL=4.8psf; BCDL=4.2psf; h=25ft; Cat. II; Exp B; Partially Enclosed; MWFRS (envelope) exterior zone; cantilever left and right exposed; end vertical left and right exposed; Lumber DOL=1.60 plate grip DOL=1.60
- TCLL: ASCE 7-16; Pf=25.0 psf (Lum DOL = 1.15 Plate DOL = 1.15); Is=1.0; Rough Cat B; Partially Exp.; Ce=1.0; Cs=1.00; Ct=1.10
- All plates are MT20 plates unless otherwise indicated.
- This truss has been designed for a 10.0 psf bottom chord live load nonconcurrent with any other live loads.
- * This truss has been designed for a live load of 20.0psf on the bottom chord in all areas where a rectangle 3-06-00 tall by 2-00-00 wide will fit between the bottom chord and any other members.
- Refer to girder(s) for truss to truss connections.
- Provide mechanical connection (by others) of truss to bearing plate capable of withstanding 990 lb uplift at joint 10 and 830 lb uplift at joint 6.
- Use Simpson Strong-Tie LUS26 (4-10d Girder, 4-10d Truss) or equivalent spaced at 2-0-0 oc max. starting at 0-10-8 from the left end to 11-11-4 to connect truss(es) to back face of bottom chord.
- Use Simpson Strong-Tie LUS26 (4-10d Girder, 4-10d Truss) or equivalent spaced at 2-0-0 oc max. starting at 13-11-4 from the left end to 15-11-4 to connect truss(es) to back face of bottom chord.
- Fill all nail holes where hanger is in contact with lumber.

LOAD CASE(S) Standard

- Dead + Snow (balanced): Lumber Increase=1.15, Plate Increase=1.15
 Uniform Loads (lb/ft)

Vert: 1-3=-66, 3-5=-66, 6-10=-14
 Concentrated Loads (lb)
 Vert: 11=-868 (B), 12=-866 (B), 13=-862 (B), 14=-862 (B), 15=-862 (B), 16=-862 (B), 17=-862 (B), 18=-862 (B), 19=-862 (B)



October 3, 2025

WARNING - Verify design parameters and READ NOTES ON THIS AND INCLUDED MITEK REFERENCE PAGE MII-7473 rev. 1/2/2023 BEFORE USE.

Design valid for use only with MiTek® connectors. This design is based only upon parameters shown, and is for an individual building component, not a truss system. Before use, the building designer must verify the applicability of design parameters and properly incorporate this design into the overall building design. Bracing indicated is to prevent buckling of individual truss web and/or chord members only. Additional temporary and permanent bracing is always required for stability and to prevent collapse with possible personal injury and property damage. For general guidance regarding the fabrication, storage, delivery, erection and bracing of trusses and truss systems, see **ANSI/TPI1 Quality Criteria and DSB-22** available from Truss Plate Institute (www.tpin.org) and **BCSI Building Component Safety Information** available from the Structural Building Component Association (www.sbcsccomponents.com)

MiTek®

400 Sunrise Ave., Suite 270
 Roseville, CA 95661
 916.755.3571 / MiTek-US.com

Job J1183948	Truss A09	Truss Type Common Girder	Qty 1	Ply 2	NW Eastside Builders LLC Job Reference (optional)	R90572887
-----------------	--------------	-----------------------------	----------	----------	--	-----------

The Truss Company (Sumner, WA), Sumner, WA - 98390,

Run: 25.30 S Sep 17 2025 Print: 25.3.0 S Sep 17 2025 MiTek Industries, Inc. Thu Oct 02 17:24:48
ID:6tAafUgLUh8duubuvqfkQz980c-RfC?PsB70Hq3NSgPqnL8w3u1TXbGKwRcD0i7J4zJC?f

Page: 1

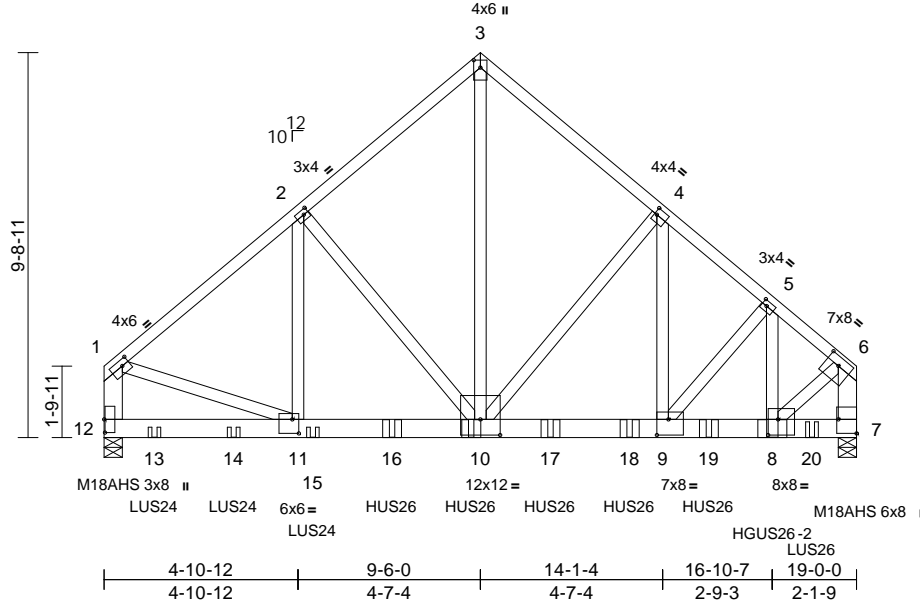

Scale = 1:58.2

Plate Offsets (X, Y): [1:0-2-4,0-1-12], [2:0-1-8,0-1-8], [3:0-2-4,0-2-0], [4:0-0-12,0-2-0], [5:0-1-8,0-1-8], [6:0-4-0,0-2-8], [7:Edge,0-5-8], [8:0-3-0,0-4-12], [9:0-3-8,0-4-12], [10:0-6-0,0-4-12], [11:0-2-0,0-4-4], [12:0-4-0,0-0-4]

Loading	(psf)	Spacing	2-0-0	CSI	DEFL	in (loc)	l/defl	L/d	PLATES	GRIP		
TCLL	25.0	Plate Grip DOL	1.15	TC	0.33	Vert(LL)	-0.11	9-10	>999	240	MT20	185/148
(Roof Snow = 25.0)		Lumber DOL	1.15	BC	0.59	Vert(CT)	-0.16	9-10	>999	180	M18AHS	169/162
TCDL	8.0	Rep Stress Incr	NO	WB	0.82	Horz(CT)	0.03	7	n/a	n/a		
BCLL	0.0*	Code	IRC2021/TPI2014	Matrix-MS								
BCDL	7.0											
											Weight: 277 lb	FT = 20%

LUMBER
TOP CHORD 2x4 HF-N No.1/No.2
BOT CHORD 2x6 DF SS
WEBS 2x4 DF Stud *Except* 12-1,7-6:2x6 DF SS, 8-6,10-3:2x4 HF-N No.1/No.2

BRACING
TOP CHORD Structural wood sheathing directly applied or 4-5-13 oc purlins, except end verticals.
BOT CHORD Rigid ceiling directly applied or 10-0-0 oc bracing.

REACTIONS (size) 7=0-5-8, (req. 0-6-1), 12=0-5-8
Max Horiz 12=-169 (LC 6)
Max Uplift 7=-1769 (LC 9), 12=-1024 (LC 8)
Max Grav 7=11385 (LC 15), 12=6719 (LC 16)

FORCES (lb) - Maximum Compression/Maximum Tension
TOP CHORD 1-2=-6489/1022, 2-3=-5792/989, 3-4=-5792/987, 4-5=-8172/1303, 5-6=-8370/1320, 1-12=-5757/895, 6-7=-10396/1620
BOT CHORD 11-12=-215/530, 10-11=-758/4983, 9-10=-909/6268, 8-9=-972/6354, 7-8=-65/384
WEBS 1-11=-680/4754, 6-8=-1182/7761, 2-11=-131/860, 2-10=-917/266, 3-10=-1153/7014, 4-10=-3013/587, 4-9=-569/3589, 5-9=-231/117, 5-8=-118/386

- All loads are considered equally applied to all plies, except if noted as front (F) or back (B) face in the LOAD CASE(S) section. Ply to ply connections have been provided to distribute only loads noted as (F) or (B), unless otherwise indicated.
- Wind: ASCE 7-16; Vult=110mph (3-second gust) Vasd=87mph; TCDL=4.8psf; BCDL=4.2psf; h=25ft; Cat. II; Exp B; Partially Enclosed; MWFRS (envelope) exterior zone; cantilever left and right exposed; end vertical left and right exposed; Lumber DOL=1.60 plate grip DOL=1.60
- TCLL: ASCE 7-16; Pf=25.0 psf (Lum DOL = 1.15 Plate DOL = 1.15); Is=1.0; Rough Cat B; Partially Exp.; Ce=1.0; Cs=1.00; Ct=1.10
- All plates are MT20 plates unless otherwise indicated.
- This truss has been designed for a 10.0 psf bottom chord live load nonconcurrent with any other live loads.
- * This truss has been designed for a live load of 20.0psf on the bottom chord in all areas where a rectangle 3-06-00 tall by 2-00-00 wide will fit between the bottom chord and any other members.
- WARNING: Required bearing size at joint(s) 7 greater than input bearing size.
- Provide mechanical connection (by others) of truss to bearing plate capable of withstanding 1024 lb uplift at joint 12 and 1769 lb uplift at joint 7.
- Use Simpson Strong-Tie LUS24 (4-SD9112 Girder, 2-SD9212 Truss, Single Ply Girder) or equivalent spaced at 2-0-0 oc max. starting at 1-3-4 from the left end to 5-3-4 to connect truss(es) to front face of bottom chord.
- Use Simpson Strong-Tie HUS26 (14-10d Girder, 6-10d Truss) or equivalent spaced at 2-0-0 oc max. starting at 7-3-4 from the left end to 15-3-4 to connect truss(es) to front face of bottom chord.
- Use Simpson Strong-Tie HGUS26-2 (20-16d Girder, 8-16d Truss) or equivalent at 16-10-8 from the left end to connect truss(es) to front face of bottom chord.

- Use Simpson Strong-Tie LUS26 (4-10d Girder, 4-10d Truss) or equivalent at 17-10-8 from the left end to connect truss(es) to front face of bottom chord.
 - Fill all nail holes where hanger is in contact with lumber.
- LOAD CASE(S)** Standard
- Dead + Snow (balanced): Lumber Increase=1.15, Plate Increase=1.15
Uniform Loads (lb/ft)
Vert: 1-3=-66, 3-6=-66, 7-12=-14
Concentrated Loads (lb)
Vert: 8=-4533 (F), 10=-1512 (F), 13=-782 (F), 14=-782 (F), 15=-782 (F), 16=-1512 (F), 17=-1512 (F), 18=-1512 (F), 19=-1512 (F), 20=-887 (F)

NOTES

- 2-ply truss to be connected together with 10d (0.131"x3") nails as follows:
Top chords connected as follows: 2x4 - 1 row at 0-6-0 oc, 2x6 - 2 rows staggered at 0-9-0 oc.
Bottom chords connected as follows: 2x6 - 3 rows staggered at 0-8-0 oc.
Web connected as follows: 2x4 - 1 row at 0-9-0 oc, Except member 5-8 2x4 - 2 rows staggered at 0-2-0 oc.



October 3, 2025

Job J1183948	Truss A10	Truss Type Common Supported Gable	Qty 1	Ply 1	NW Eastside Builders LLC Job Reference (optional)	R90572888
-----------------	--------------	--------------------------------------	----------	----------	--	-----------

The Truss Company (Sumner, WA), Sumner, WA - 98390,

Run: 25.30 S Sep 17 2025 Print: 25.3.0 S Sep 17 2025 MiTek Industries, Inc. Thu Oct 02 17:24:48
ID:bfNf6pqYknXThBjyitrn7z9DZf-RfC?PsB70Hq3NSgPqnL8w3uITxbGKWrCDoi7J4zJC?f

Page: 1

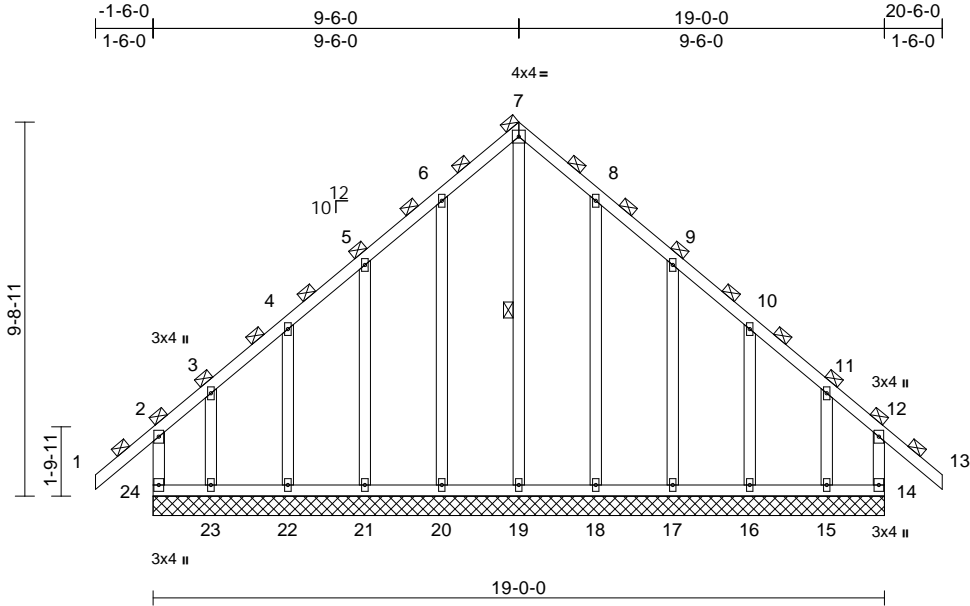

Scale = 1:59.9

Loading	(psf)	Spacing	2-6-0	CSI	DEFL	in	(loc)	l/defl	L/d	PLATES	GRIP	
TCLL	25.0	Plate Grip DOL	1.15	TC	0.27	Vert(LL)	n/a	-	n/a	999	MT20	185/148
(Roof Snow = 25.0)		Lumber DOL	1.15	BC	0.13	Vert(CT)	n/a	-	n/a	999		
TCDL	8.0	Rep Stress Incr	NO	WB	0.19	Horz(CT)	0.00	14	n/a	n/a		
BCLL	0.0*	Code	IRC2021/TPI2014	Matrix-MR								
BCDL	7.0											
											Weight: 128 lb	FT = 20%

LUMBER

TOP CHORD	2x4 HF-N No.1/No.2
BOT CHORD	2x4 HF-N No.1/No.2
WEBS	2x4 DF Stud
OTHERS	2x4 DF Stud *Except* 19-7,20-6,18-8:2x4 HF-N No.1/No.2

BRACING

TOP CHORD	2-0-0 oc purlins (6-0-0 max.), except end verticals
BOT CHORD	Rigid ceiling directly applied or 6-0-0 oc bracing.
WEBS	1 Row at midpt 7-19

REACTIONS (size)

14=19-0-0, 15=19-0-0, 16=19-0-0, 17=19-0-0, 18=19-0-0, 19=19-0-0, 20=19-0-0, 21=19-0-0, 22=19-0-0, 23=19-0-0, 24=19-0-0
Max Horiz 24=241 (LC 8)
Max Uplift 14=179 (LC 7), 15=207 (LC 6), 16=86 (LC 11), 17=109 (LC 11), 18=86 (LC 11), 19=37 (LC 9), 20=86 (LC 10), 21=109 (LC 10), 22=85 (LC 10), 23=218 (LC 7), 24=195 (LC 6)
Max Grav 14=312 (LC 18), 15=277 (LC 9), 16=218 (LC 19), 17=224 (LC 19), 18=231 (LC 19), 19=384 (LC 11), 20=232 (LC 18), 21=225 (LC 18), 22=217 (LC 18), 23=289 (LC 8), 24=325 (LC 19)

FORCES (lb) - Maximum Compression/Maximum Tension

2-24=-265/202, 1-2=0/87, 2-3=-164/177, 3-4=-117/171, 4-5=-128/275, 5-6=-177/378, 6-7=-233/463, 7-8=-233/463, 8-9=-177/378, 9-10=-118/274, 10-11=-108/174, 11-12=-150/164, 12-13=0/87, 12-14=-256/171
--

BOT CHORD

23-24=-139/130, 22-23=-139/130, 21-22=-139/130, 20-21=-139/130, 19-20=-139/130, 18-19=-139/130, 17-18=-139/130, 16-17=-139/130, 15-16=-139/130, 14-15=-139/130
--

WEBS

7-19=503/184, 6-20=197/109, 5-21=187/137, 4-22=193/138, 3-23=170/145, 8-18=197/109, 9-17=187/138, 10-16=194/133, 11-15=165/139
--

- NOTES**
- 1) Wind: ASCE 7-16; Vult=110mph (3-second gust) Vasd=87mph; TCLL=4.8psf; BCDL=4.2psf; h=25ft; Cat. II; Exp B; Partially Enclosed; MWFRS (envelope) exterior zone and C-C Corner(3E) -1-6-0 to 1-6-0, Exterior(2N) 1-6-0 to 6-6-0, Corner(3R) 6-6-0 to 12-6-0, Exterior(2N) 12-6-0 to 17-6-0, Corner(3E) 17-6-0 to 20-6-0 zone; cantilever left and right exposed; end vertical left and right exposed; C-C for members and forces & MWFRS for reactions shown; Lumber DOL=1.60 plate grip DOL=1.60
 - 2) Truss designed for wind loads in the plane of the truss only. For studs exposed to wind (normal to the face), see Standard Industry Gable End Details as applicable, or consult qualified building designer as per ANSI/TPI 1.
 - 3) TCLL: ASCE 7-16; Pf=25.0 psf (Lum DOL = 1.15 Plate DOL = 1.15); Is=1.0; Rough Cat B; Partially Exp.; Ce=1.0; Cs=1.00; Ct=1.10
 - 4) This truss has been designed for greater of min roof live load of 16.0 psf or 1.00 times flat roof load of 25.0 psf on overhangs non-concurrent with other live loads.
 - 5) All plates are 2x4 (||) MT20 unless otherwise indicated.
 - 6) Gable requires continuous bottom chord bearing.
 - 7) Truss to be fully sheathed from one face or securely braced against lateral movement (i.e. diagonal web).
 - 8) Gable studs spaced at 2-0-0 oc.
 - 9) This truss has been designed for a 10.0 psf bottom chord live load nonconcurrent with any other live loads.

- 10) * This truss has been designed for a live load of 20.0psf on the bottom chord in all areas where a rectangle 3-06-00 tall by 2-00-00 wide will fit between the bottom chord and any other members.
 - 11) Provide mechanical connection (by others) of truss to bearing plate capable of withstanding 195 lb uplift at joint 24, 179 lb uplift at joint 14, 37 lb uplift at joint 19, 86 lb uplift at joint 20, 109 lb uplift at joint 21, 85 lb uplift at joint 22, 218 lb uplift at joint 23, 86 lb uplift at joint 18, 109 lb uplift at joint 17, 86 lb uplift at joint 16 and 207 lb uplift at joint 15.
 - 12) Graphical purlin representation does not depict the size or the orientation of the purlin along the top and/or bottom chord.
- LOAD CASE(S)** Standard



October 3, 2025

WARNING - Verify design parameters and READ NOTES ON THIS AND INCLUDED MITEK REFERENCE PAGE MII-7473 rev. 1/2/2023 BEFORE USE.

Design valid for use only with MiTek® connectors. This design is based only upon parameters shown, and is for an individual building component, not a truss system. Before use, the building designer must verify the applicability of design parameters and properly incorporate this design into the overall building design. Bracing indicated is to prevent buckling of individual truss web and/or chord members only. Additional temporary and permanent bracing is always required for stability and to prevent collapse with possible personal injury and property damage. For general guidance regarding the fabrication, storage, delivery, erection and bracing of trusses and truss systems, see **ANSI/TPI1 Quality Criteria and DSB-22** available from Truss Plate Institute (www.tpinst.org) and **BCSI Building Component Safety Information** available from the Structural Building Component Association (www.sbcsc.com).

MiTek®

400 Sunrise Ave., Suite 270
Roseville, CA 95661
916.755.3571 / MiTek-US.com

Job J1183948	Truss A12	Truss Type Scissor	Qty 1	Ply 1	NW Eastside Builders LLC Job Reference (optional)	R90572890
-----------------	--------------	-----------------------	----------	----------	--	-----------

The Truss Company (Sumner, WA), Sumner, WA - 98390,

Run: 25.30 S Sep 17 2025 Print: 25.3.0 S Sep 17 2025 MiTek Industries, Inc. Thu Oct 02 17:24:48
ID:PyZoY4Y3qctXRL7glpfJKJz980y-RfC?PsB70Hq3NSgPqnL8w3uTXbGKWrCDoi7J4zJC?f

Page: 1

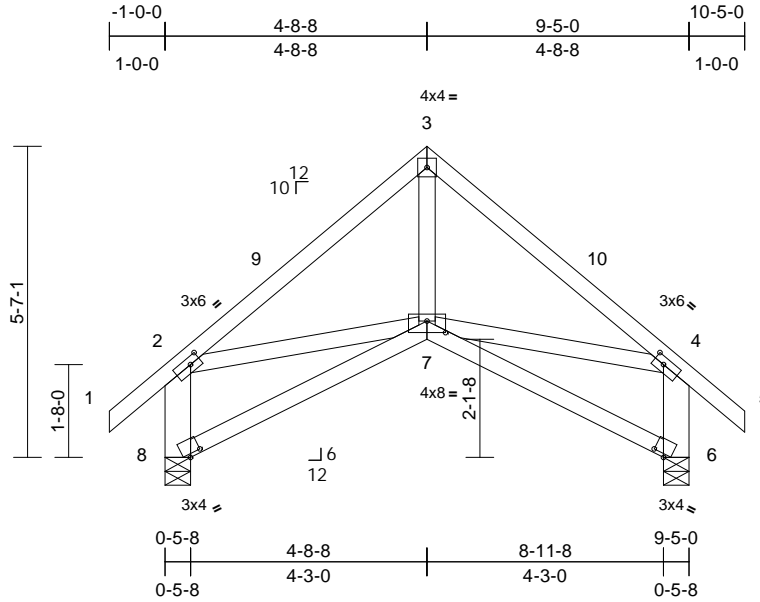

Scale = 1:41.4

Plate Offsets (X, Y): [2:0-2-4,0-1-8], [4:0-2-4,0-1-8], [6:0-2-10,0-0-12], [7:0-4-0,0-2-8], [8:0-2-10,0-0-12]

Loading	(psf)	Spacing	2-0-0	CSI	DEFL	in	(loc)	l/defl	L/d	PLATES	GRIP	
TCLL (Roof Snow = 25.0)	25.0	Plate Grip DOL	1.15	TC	0.20	Vert(LL)	-0.01	7-8	>999	240	MT20	185/148
TCDL	8.0	Lumber DOL	1.15	BC	0.10	Vert(CT)	-0.02	7-8	>999	180		
BCLL	0.0*	Rep Stress Incr	YES	WB	0.07	Horz(CT)	0.01	6	n/a	n/a		
BCDL	7.0	Code	IRC2021/TPI2014	Matrix-MS								
											Weight: 54 lb	FT = 20%

LUMBER

TOP CHORD 2x4 HF-N No.1/No.2
 BOT CHORD 2x4 HF-N No.1/No.2
 WEBS 2x4 DF Stud *Except* 8-2,6-4:2x6 DF SS

BRACING

TOP CHORD Structural wood sheathing directly applied or 6-0-0 oc purlins, except end verticals.
 BOT CHORD Rigid ceiling directly applied or 10-0-0 oc bracing.

REACTIONS

(size) 6=0-5-8, 8=0-5-8
 Max Horiz 8=-120 (LC 8)
 Max Uplift 6=-61 (LC 11), 8=-61 (LC 10)
 Max Grav 6=439 (LC 1), 8=439 (LC 1)

FORCES

(lb) - Maximum Compression/Maximum Tension
 TOP CHORD 1-2=0/52, 2-3=-448/48, 3-4=-451/59,
 4-5=0/52, 2-8=-437/162, 4-6=-437/167
 BOT CHORD 7-8=-137/184, 6-7=-53/119
 WEBS 3-7=-5/225, 2-7=0/205, 4-7=-50/236

NOTES

- 1) Wind: ASCE 7-16; Vult=110mph (3-second gust) Vasd=87mph; TCDL=4.8psf; BCDL=4.2psf; h=25ft; Cat. II; Exp B; Partially Enclosed; MWFRS (envelope) exterior zone and C-C Exterior(2E) -1-0-0 to 2-0-0, Exterior(2R) 2-0-0 to 7-5-0, Exterior(2E) 7-5-0 to 10-5-0 zone; cantilever left and right exposed; end vertical left and right exposed; C-C for members and forces & MWFRS for reactions shown; Lumber DOL=1.60 plate grip DOL=1.60
- 2) TCLL: ASCE 7-16; Pf=25.0 psf (Lum DOL = 1.15 Plate DOL = 1.15); Is=1.0; Rough Cat B; Partially Exp.; Ce=1.0; Cs=1.00; Ct=1.10
- 3) This truss has been designed for greater of min roof live load of 16.0 psf or 1.00 times flat roof load of 25.0 psf on overhangs non-concurrent with other live loads.
- 4) This truss has been designed for a 10.0 psf bottom chord live load nonconcurrent with any other live loads.

5) * This truss has been designed for a live load of 20.0psf on the bottom chord in all areas where a rectangle 3-06-00 tall by 2-00-00 wide will fit between the bottom chord and any other members.

6) Bearing at joint(s) 8, 6 considers parallel to grain value using ANSI/TPI 1 angle to grain formula. Building designer should verify capacity of bearing surface.

7) Provide mechanical connection (by others) of truss to bearing plate capable of withstanding 61 lb uplift at joint 8 and 61 lb uplift at joint 6.

LOAD CASE(S) Standard



October 3, 2025

WARNING - Verify design parameters and READ NOTES ON THIS AND INCLUDED MITEK REFERENCE PAGE MII-7473 rev. 1/2/2023 BEFORE USE.

Design valid for use only with MiTek® connectors. This design is based only upon parameters shown, and is for an individual building component, not a truss system. Before use, the building designer must verify the applicability of design parameters and properly incorporate this design into the overall building design. Bracing indicated is to prevent buckling of individual truss web and/or chord members only. Additional temporary and permanent bracing is always required for stability and to prevent collapse with possible personal injury and property damage. For general guidance regarding the fabrication, storage, delivery, erection and bracing of trusses and truss systems, see **ANSI/TPI1 Quality Criteria and DSB-22** available from Truss Plate Institute (www.tpinst.org) and **BCSI Building Component Safety Information** available from the Structural Building Component Association (www.sbcsccomponents.com)

MiTek®

400 Sunrise Ave., Suite 270
 Roseville, CA 95661
 916.755.3571 / MiTek-US.com

Job J1183948	Truss A13	Truss Type Scissor	Qty 3	Ply 1	NW Eastside Builders LLC Job Reference (optional)	R90572891
-----------------	--------------	-----------------------	----------	----------	--	-----------

The Truss Company (Sumner, WA), Sumner, WA - 98390,

Run: 25.30 S Sep 17 2025 Print: 25.3.0 S Sep 17 2025 MiTek Industries, Inc. Thu Oct 02 17:24:48
ID:PyZoY4Y3qctXRL7glpfJKJz980y-RfC?PsB70Hq3NSgPqnL8w3uTXbGKWrCDoi7J4zJC?f

Page: 1

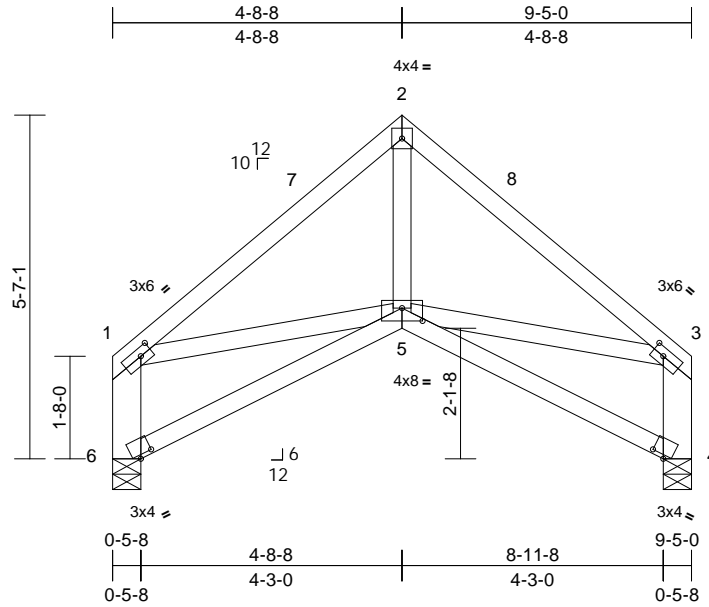

Scale = 1:37.5

Plate Offsets (X, Y): [1:0-2-4,0-1-8], [3:0-2-4,0-1-8], [4:0-2-10,0-0-12], [5:0-4-0,0-2-8], [6:0-2-10,0-0-12]

Loading	(psf)	Spacing	2-0-0	CSI	DEFL	in	(loc)	l/defl	L/d	PLATES	GRIP	
TCLL (Roof Snow = 25.0)	25.0	Plate Grip DOL	1.15	TC	0.19	Vert(LL)	-0.01	5-6	>999	240	MT20	185/148
TCDL	8.0	Lumber DOL	1.15	BC	0.10	Vert(CT)	-0.02	5-6	>999	180		
BCLL	0.0*	Rep Stress Incr	YES	WB	0.08	Horz(CT)	0.01	4	n/a	n/a		
BCDL	7.0	Code	IRC2021/TPI2014	Matrix-MS								
											Weight: 50 lb	FT = 20%

LUMBER

TOP CHORD 2x4 HF-N No.1/No.2
 BOT CHORD 2x4 HF-N No.1/No.2
 WEBS 2x4 DF Stud *Except* 6-1,4-3:2x6 DF SS

BRACING

TOP CHORD Structural wood sheathing directly applied or 6-0-0 oc purlins, except end verticals.
 BOT CHORD Rigid ceiling directly applied or 10-0-0 oc bracing.

REACTIONS (size) 4=0-5-8, 6=0-5-8

Max Horiz 6=-103 (LC 8)
 Max Uplift 4=-47 (LC 10), 6=-47 (LC 11)
 Max Grav 4=358 (LC 1), 6=358 (LC 1)

FORCES (lb) - Maximum Compression/Maximum Tension

TOP CHORD 1-2=-465/71, 2-3=-465/71, 1-6=-354/111, 3-4=-353/116
 BOT CHORD 5-6=-120/151, 4-5=-40/80
 WEBS 2-5=-3/225, 1-5=0/232, 3-5=-30/251

NOTES

- 1) Wind: ASCE 7-16; Vult=110mph (3-second gust) Vasd=87mph; TCDL=4.8psf; BCDL=4.2psf; h=25ft; Cat. II; Exp B; Partially Enclosed; MWFRS (envelope) exterior zone and C-C Exterior(2E) 0-2-12 to 3-2-12, Exterior(2R) 3-2-12 to 6-2-4, Exterior(2E) 6-2-4 to 9-2-4 zone; cantilever left and right exposed; end vertical left and right exposed; C-C for members and forces & MWFRS for reactions shown; Lumber DOL=1.60 plate grip DOL=1.60
- 2) TCLL: ASCE 7-16; Pf=25.0 psf (Lum DOL = 1.15 Plate DOL = 1.15); Is=1.0; Rough Cat B; Partially Exp.; Ce=1.0; Cs=1.00; Ct=1.10
- 3) This truss has been designed for a 10.0 psf bottom chord live load nonconcurrent with any other live loads.

4) * This truss has been designed for a live load of 20.0psf on the bottom chord in all areas where a rectangle 3-06-00 tall by 2-00-00 wide will fit between the bottom chord and any other members.

- 5) Bearing at joint(s) 6, 4 considers parallel to grain value using ANSI/TPI 1 angle to grain formula. Building designer should verify capacity of bearing surface.
- 6) Provide mechanical connection (by others) of truss to bearing plate capable of withstanding 47 lb uplift at joint 6 and 47 lb uplift at joint 4.

LOAD CASE(S) Standard



October 3, 2025

WARNING - Verify design parameters and READ NOTES ON THIS AND INCLUDED MITEK REFERENCE PAGE MII-7473 rev. 1/2/2023 BEFORE USE.

Design valid for use only with MiTek® connectors. This design is based only upon parameters shown, and is for an individual building component, not a truss system. Before use, the building designer must verify the applicability of design parameters and properly incorporate this design into the overall building design. Bracing indicated is to prevent buckling of individual truss web and/or chord members only. Additional temporary and permanent bracing is always required for stability and to prevent collapse with possible personal injury and property damage. For general guidance regarding the fabrication, storage, delivery, erection and bracing of trusses and truss systems, see **ANSI/TPI1 Quality Criteria and DSB-22** available from Truss Plate Institute (www.tpinst.org) and **BCSI Building Component Safety Information** available from the Structural Building Component Association (www.sbcsccomponents.com)

MiTek®

400 Sunrise Ave., Suite 270
 Roseville, CA 95661
 916.755.3571 / MiTek-US.com

Job J1183948	Truss A14	Truss Type Scissor	Qty 3	Ply 1	NW Eastside Builders LLC Job Reference (optional)	R90572892
-----------------	--------------	-----------------------	----------	----------	--	-----------

The Truss Company (Sumner, WA), Sumner, WA - 98390,

Run: 25.30 S Sep 17 2025 Print: 25.3.0 S Sep 17 2025 MiTek Industries, Inc. Thu Oct 02 17:24:48
ID:JaV7eJ2CG0NkUH47M9Gyixz9W0k-RfC?PsB70Hq3NSgPqnL8w3uiTXbGKWrCD0i7J4zJC?i

Page: 1

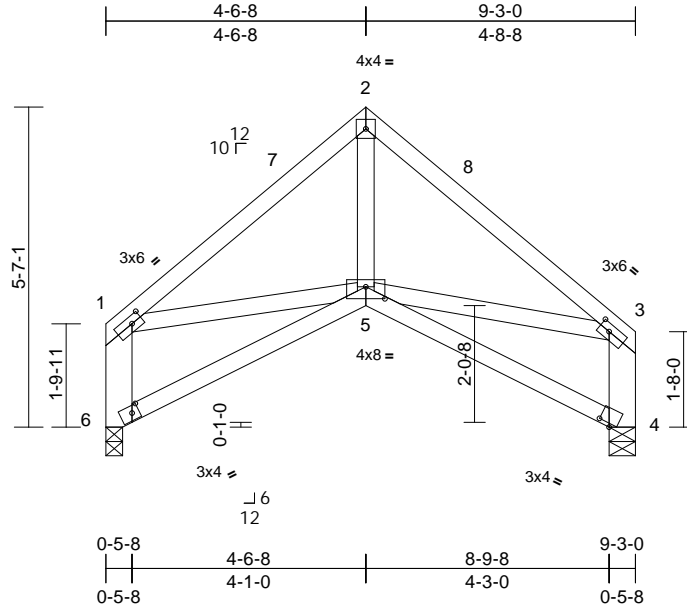

Scale = 1:40.2

Plate Offsets (X, Y): [1:0-2-4,0-1-8], [3:0-2-4,0-1-8], [4:0-2-10,0-0-12], [5:0-4-0,0-2-8], [6:0-1-8,0-1-8]

Loading	(psf)	Spacing	2-0-0	CSI	DEFL	in	(loc)	l/defl	L/d	PLATES	GRIP	
TCLL	25.0	Plate Grip DOL	1.15	TC	0.19	Vert(LL)	-0.01	4-5	>999	240	MT20	185/148
(Roof Snow = 25.0)		Lumber DOL	1.15	BC	0.10	Vert(CT)	-0.02	4-5	>999	180		
TCDL	8.0	Rep Stress Incr	YES	WB	0.08	Horz(CT)	0.01	4	n/a	n/a		
BCLL	0.0*	Code	IRC2021/TPI2014	Matrix-MS								
BCDL	7.0											
											Weight: 50 lb	FT = 20%

LUMBER

TOP CHORD 2x4 HF-N No.1/No.2
 BOT CHORD 2x4 HF-N No.1/No.2
 WEBS 2x4 DF Stud *Except* 6-1,4-3:2x6 DF SS

BRACING

TOP CHORD Structural wood sheathing directly applied or 6-0-0 oc purlins, except end verticals.
 BOT CHORD Rigid ceiling directly applied or 10-0-0 oc bracing.

REACTIONS (size) 4=0-5-8, 6=0-3-8

Max Horiz 6=-104 (LC 6)
 Max Uplift 4=-45 (LC 10), 6=-47 (LC 11)
 Max Grav 4=352 (LC 1), 6=352 (LC 1)

FORCES (lb) - Maximum Compression/Maximum Tension

TOP CHORD 1-2=-447/69, 2-3=-452/67, 1-6=-344/106, 3-4=-346/115
 BOT CHORD 5-6=-115/144, 4-5=-40/81
 WEBS 2-5=-4/216, 1-5=0/227, 3-5=-29/240

NOTES

- 1) Wind: ASCE 7-16; Vult=110mph (3-second gust) Vasd=87mph; TCDL=4.8psf; BCDL=4.2psf; h=25ft; Cat. II; Exp B; Partially Enclosed; MWFRS (envelope) exterior zone and C-C Exterior(2E) 0-2-12 to 3-2-12, Exterior(2R) 3-2-12 to 6-0-4, Exterior(2E) 6-0-4 to 9-0-4 zone; cantilever left and right exposed; end vertical left and right exposed; C-C for members and forces & MWFRS for reactions shown; Lumber DOL=1.60 plate grip DOL=1.60
- 2) TCLL: ASCE 7-16; Pf=25.0 psf (Lum DOL = 1.15 Plate DOL = 1.15); Is=1.0; Rough Cat B; Partially Exp.; Ce=1.0; Cs=1.00; Ct=1.10
- 3) This truss has been designed for a 10.0 psf bottom chord live load nonconcurrent with any other live loads.

4) * This truss has been designed for a live load of 20.0psf on the bottom chord in all areas where a rectangle 3-06-00 tall by 2-00-00 wide will fit between the bottom chord and any other members.

- 5) Bearing at joint(s) 6, 4 considers parallel to grain value using ANSI/TPI 1 angle to grain formula. Building designer should verify capacity of bearing surface.
- 6) Provide mechanical connection (by others) of truss to bearing plate capable of withstanding 47 lb uplift at joint 6 and 45 lb uplift at joint 4.

LOAD CASE(S) Standard



October 3, 2025

WARNING - Verify design parameters and READ NOTES ON THIS AND INCLUDED MITEK REFERENCE PAGE MII-7473 rev. 1/2/2023 BEFORE USE.

Design valid for use only with MiTek® connectors. This design is based only upon parameters shown, and is for an individual building component, not a truss system. Before use, the building designer must verify the applicability of design parameters and properly incorporate this design into the overall building design. Bracing indicated is to prevent buckling of individual truss web and/or chord members only. Additional temporary and permanent bracing is always required for stability and to prevent collapse with possible personal injury and property damage. For general guidance regarding the fabrication, storage, delivery, erection and bracing of trusses and truss systems, see **ANSI/TPI1 Quality Criteria and DSB-22** available from Truss Plate Institute (www.tpinst.org) and **BCSI Building Component Safety Information** available from the Structural Building Component Association (www.sbcsccomponents.com)

MiTek®

400 Sunrise Ave., Suite 270
 Roseville, CA 95661
 916.755.3571 / MiTek-US.com

Job J1183948	Truss A15	Truss Type Common Girder	Qty 1	Ply 1	NW Eastside Builders LLC Job Reference (optional)	R90572893
-----------------	--------------	-----------------------------	----------	----------	--	-----------

The Truss Company (Sumner, WA), Sumner, WA - 98390,

Run: 25.30 S Sep 17 2025 Print: 25.3.0 S Sep 17 2025 MiTek Industries, Inc. Thu Oct 02 17:24:48
ID:ehcCR9tjN0F0kJPkCJQBDz980p-RfC?PsB70Hq3NSgPqnL8w3uTXbGKWrCD0i7J4zJC?f

Page: 1

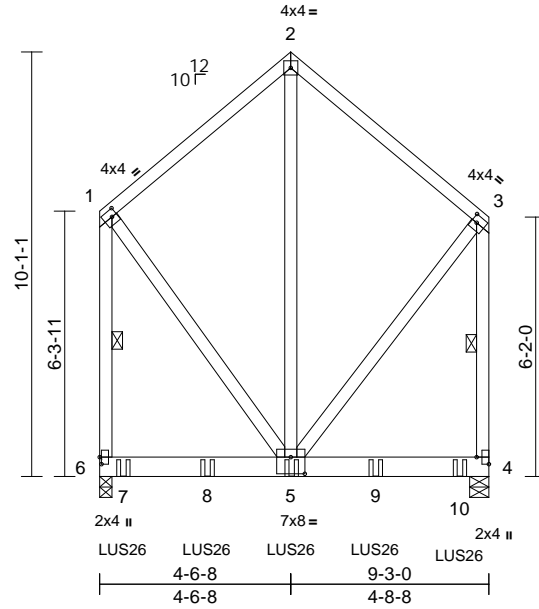

Scale = 1:54.8

Plate Offsets (X, Y): [1:0-1-8,0-2-0], [3:0-1-8,0-2-0], [4:Edge,0-3-8], [5:0-4-0,0-4-12], [6:0-2-0,0-0-8]

Loading	(psf)	Spacing	2-0-0	CSI	DEFL	in	(loc)	l/defl	L/d	PLATES	GRIP	
TCLL (Roof Snow = 25.0)	25.0	Plate Grip DOL	1.15	TC	0.43	Vert(LL)	-0.04	4-5	>999	240	MT20	185/148
TCDL	8.0	Lumber DOL	1.15	BC	0.46	Vert(CT)	-0.07	4-5	>999	180		
BCLL	0.0*	Rep Stress Incr	NO	WB	0.35	Horz(CT)	0.00	4	n/a	n/a		
BCDL	7.0	Code	IRC2021/TPI2014	Matrix-MS								
											Weight: 80 lb	FT = 20%

LUMBER

TOP CHORD 2x4 HF-N No.1/No.2
 BOT CHORD 2x6 DF SS
 WEBS 2x4 HF-N No.1/No.2 *Except* 6-1,4-3:2x4 DF Stud

BRACING

TOP CHORD Structural wood sheathing directly applied or 5-11-13 oc purlins, except end verticals.
 BOT CHORD Rigid ceiling directly applied or 10-0-0 oc bracing.
 WEBS 1 Row at midpt 1-6, 3-4

REACTIONS

(size) 4=0-5-8, 6=0-3-8
 Max Horiz 6=-209 (LC 6)
 Max Uplift 4=-535 (LC 5), 6=-551 (LC 4)
 Max Grav 4=2564 (LC 15), 6=2628 (LC 16)

FORCES

(lb) - Maximum Compression/Maximum Tension
 TOP CHORD 1-2=-960/269, 2-3=-965/265, 1-6=-1588/348, 3-4=-1539/336
 BOT CHORD 5-6=-208/204, 4-5=-72/67
 WEBS 2-5=-236/853, 1-5=-275/1127, 3-5=-265/1081

NOTES

- 1) Wind: ASCE 7-16; Vult=110mph (3-second gust)
 Vasd=87mph; TCDL=4.8psf; BCDL=4.2psf; h=25ft; Cat. II; Exp B; Partially Enclosed; MWFRS (envelope) exterior zone; cantilever left and right exposed; end vertical left and right exposed; Lumber DOL=1.60 plate grip DOL=1.60
- 2) TCLL: ASCE 7-16; Pf=25.0 psf (Lum DOL = 1.15 Plate DOL = 1.15); Is=1.0; Rough Cat B; Partially Exp.; Ce=1.0; Cs=1.00; Ct=1.10
- 3) This truss has been designed for a 10.0 psf bottom chord live load nonconcurrent with any other live loads.
- 4) * This truss has been designed for a live load of 20.0psf on the bottom chord in all areas where a rectangle 3-06-00 tall by 2-00-00 wide will fit between the bottom chord and any other members.

- 5) Provide mechanical connection (by others) of truss to bearing plate capable of withstanding 551 lb uplift at joint 6 and 535 lb uplift at joint 4.
- 6) Use Simpson Strong-Tie LUS26 (4-10d Girder, 4-10d Truss, Single Ply Girder) or equivalent spaced at 2-0-0 oc max. starting at 0-6-12 from the left end to 8-6-12 to connect truss(es) to back face of bottom chord.
- 7) Fill all nail holes where hanger is in contact with lumber.
- 8) In the LOAD CASE(S) section, loads applied to the face of the truss are noted as front (F) or back (B).

LOAD CASE(S) Standard

- 1) Dead + Snow (balanced): Lumber Increase=1.15, Plate Increase=1.15
 Uniform Loads (lb/ft)
 Vert: 1-2=-66, 2-3=-66, 4-6=-14
 Concentrated Loads (lb)
 Vert: 5=-783 (B), 7=-782 (B), 8=-783 (B), 9=-783 (B), 10=-786 (B)



October 3, 2025

WARNING - Verify design parameters and READ NOTES ON THIS AND INCLUDED MITEK REFERENCE PAGE MII-7473 rev. 1/2/2023 BEFORE USE.

Design valid for use only with MiTek® connectors. This design is based only upon parameters shown, and is for an individual building component, not a truss system. Before use, the building designer must verify the applicability of design parameters and properly incorporate this design into the overall building design. Bracing indicated is to prevent buckling of individual truss web and/or chord members only. Additional temporary and permanent bracing is always required for stability and to prevent collapse with possible personal injury and property damage. For general guidance regarding the fabrication, storage, delivery, erection and bracing of trusses and truss systems, see **ANSI/TPI1 Quality Criteria and DSB-22** available from Truss Plate Institute (www.tpinst.org) and **BCSI Building Component Safety Information** available from the Structural Building Component Association (www.sbcsccomponents.com)

MiTek®

400 Sunrise Ave., Suite 270
 Roseville, CA 95661
 916.755.3571 / MiTek-US.com

Job J1183948	Truss B01	Truss Type Common Supported Gable	Qty 2	Ply 1	NW Eastside Builders LLC Job Reference (optional)	R90572894
-----------------	--------------	--------------------------------------	----------	----------	--	-----------

The Truss Company (Sumner, WA), Sumner, WA - 98390,

Run: 25.30 S Sep 17 2025 Print: 25.3.0 S Sep 17 2025 MiTek Industries, Inc. Thu Oct 02 17:24:49
ID:LhYzlaKME7Fgfh3QEhnPkz980w-RfC?PsB70Hq3NSgPqnLw3uTXbGKwRcDoi7J4zJC?f

Page: 1

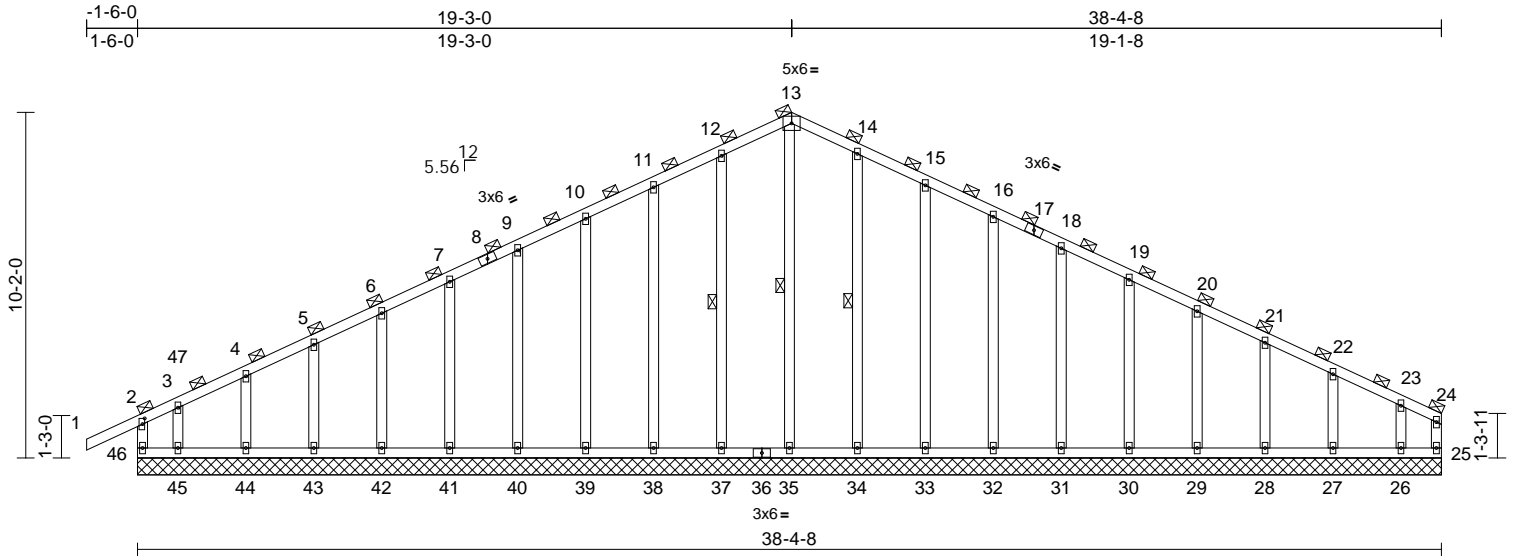

Scale = 1:67.8

Plate Offsets (X, Y): [2:0-2-0,0-0-12]

Loading	(psf)	Spacing	2-6-0	CSI	DEFL	in	(loc)	l/defl	L/d	PLATES	GRIP	
TCLL	25.0	Plate Grip DOL	1.15	TC	0.22	Vert(LL)	n/a	-	n/a	999	MT20	185/148
(Roof Snow = 25.0)		Lumber DOL	1.15	BC	0.07	Vert(CT)	n/a	-	n/a	999		
TCDL	8.0	Rep Stress Incr	NO	WB	0.28	Horz(CT)	0.00	25	n/a	n/a		
BCLL	0.0*	Code	IRC2021/TPI2014	Matrix-MR								
BCDL	7.0											
											Weight: 236 lb	FT = 20%

LUMBER
TOP CHORD 2x4 HF-N No.1/No.2
BOT CHORD 2x4 HF-N No.1/No.2
WEBS 2x4 DF Stud
OTHERS 2x4 DF Stud *Except*
35-13,37-12,38-11,34-14,33-15:2x4 HF-N No.1/No.2

BRACING
TOP CHORD 2-0-0 oc purlins (6-0-0 max.), except end verticals
(Switched from sheeted: Spacing > 2-0-0).
BOT CHORD Rigid ceiling directly applied or 6-0-0 oc bracing.

WEBS 1 Row at midpt 13-35, 12-37, 14-34
REACTIONS (size) 25=38-4-8, 26=38-4-8, 27=38-4-8, 28=38-4-8, 29=38-4-8, 30=38-4-8, 31=38-4-8, 32=38-4-8, 33=38-4-8, 34=38-4-8, 35=38-4-8, 37=38-4-8, 38=38-4-8, 39=38-4-8, 40=38-4-8, 41=38-4-8, 42=38-4-8, 43=38-4-8, 44=38-4-8, 45=38-4-8, 46=38-4-8
Max Horiz 46=120 (LC 12)
Max Uplift 25=54 (LC 16), 26=155 (LC 13), 27=49 (LC 13), 28=61 (LC 13), 29=58 (LC 13), 30=58 (LC 13), 31=59 (LC 13), 32=57 (LC 13), 33=64 (LC 13), 34=47 (LC 13), 37=53 (LC 12), 38=63 (LC 12), 39=57 (LC 12), 40=59 (LC 12), 41=59 (LC 12), 42=58 (LC 12), 43=61 (LC 12), 44=47 (LC 12), 45=170 (LC 12), 46=62 (LC 17)

Max Grav 25=126 (LC 13), 26=190 (LC 24), 27=206 (LC 20), 28=199 (LC 1), 29=200 (LC 1), 30=201 (LC 20), 31=200 (LC 1), 32=247 (LC 20), 33=298 (LC 20), 34=306 (LC 20), 35=219 (LC 13), 37=314 (LC 19), 38=293 (LC 19), 39=246 (LC 19), 40=200 (LC 1), 41=200 (LC 19), 42=201 (LC 1), 43=196 (LC 19), 44=218 (LC 1), 45=125 (LC 17), 46=274 (LC 1)

WEBS 13-35=256/65, 12-37=279/77, 11-38=258/94, 10-39=211/86, 9-40=165/88, 7-41=165/88, 6-42=166/88, 5-43=162/86, 4-44=180/94, 3-45=94/119, 14-34=271/71, 15-33=263/95, 16-32=212/86, 18-31=165/88, 19-30=166/88, 20-29=165/88, 21-28=164/85, 22-27=170/107, 23-26=145/149

FORCES (lb) - Maximum Compression/Maximum Tension
TOP CHORD 2-46=256/125, 1-2=0/57, 2-3=132/85, 3-4=89/86, 4-5=77/111, 5-6=63/140, 6-7=69/174, 7-9=92/221, 9-10=115/268, 10-11=137/314, 11-12=161/364, 12-13=183/406, 24-25=72/34, 13-14=183/405, 14-15=162/365, 15-16=138/315, 16-18=116/269, 18-19=93/222, 19-20=70/175, 20-21=47/128, 21-22=56/86, 22-23=64/64, 23-24=104/65
BOT CHORD 45-46=43/93, 44-45=43/93, 43-44=43/93, 42-43=43/93, 41-42=43/93, 40-41=43/93, 39-40=43/93, 38-39=43/93, 37-38=43/93, 35-37=43/93, 34-35=43/94, 33-34=43/94, 32-33=43/94, 31-32=43/94, 30-31=43/94, 29-30=43/94, 28-29=43/94, 27-28=43/94, 26-27=43/94, 25-26=43/94

NOTES
1) Wind: ASCE 7-16; Vult=110mph (3-second gust) Vasd=87mph; TCDL=4.8psf; BCDL=4.2psf; h=25ft; Cat. II; Exp B; Partially Enclosed; MWFRS (envelope) exterior zone and C-C Corner(3E) -1-6-0 to 1-6-0, Exterior(2N) 1-6-0 to 16-3-0, Corner(3R) 16-3-0 to 22-3-0, Exterior(2N) 22-3-0 to 35-2-4, Corner(3E) 35-2-4 to 38-2-12 zone; cantilever left and right exposed ; end and vertical left and right exposed;C-C for members and forces & MWFRS for reactions shown; Lumber DOL=1.60 plate grip DOL=1.60



October 3, 2025

Continued on page 2

WARNING - Verify design parameters and READ NOTES ON THIS AND INCLUDED MITEK REFERENCE PAGE MII-7473 rev. 1/2/2023 BEFORE USE.

Design valid for use only with MiTek® connectors. This design is based only upon parameters shown, and is for an individual building component, not a truss system. Before use, the building designer must verify the applicability of design parameters and properly incorporate this design into the overall building design. Bracing indicated is to prevent buckling of individual truss web and/or chord members only. Additional temporary and permanent bracing is always required for stability and to prevent collapse with possible personal injury and property damage. For general guidance regarding the fabrication, storage, delivery, erection and bracing of trusses and truss systems, see **ANSI/TPI1 Quality Criteria and DSB-22** available from Truss Plate Institute (www.tpinst.org) and **BCSI Building Component Safety Information** available from the Structural Building Component Association (www.sbcsccomponents.com)

MiTek®
400 Sunrise Ave., Suite 270
Roseville, CA 95661
916.755.3571 / MiTek-US.com

Job	Truss	Truss Type	Qty	Ply	NW Eastside Builders LLC	R90572894
J1183948	B01	Common Supported Gable	2	1	Job Reference (optional)	

The Truss Company (Sumner, WA), Sumner, WA - 98390,

Run: 25.30 S Sep 17 2025 Print: 25.3.0 S Sep 17 2025 MiTek Industries, Inc. Thu Oct 02 17:24:49
ID:LLhYzlaKME7FgfH3QEhnPkz980w-RfC?PsB70Hq3NSgPqnL8w3ulTXbGKWrCDoi7J4zJC?i

Page: 2

- 2) Truss designed for wind loads in the plane of the truss only. For studs exposed to wind (normal to the face), see Standard Industry Gable End Details as applicable, or consult qualified building designer as per ANSI/TPI 1.
- 3) TCELL: ASCE 7-16; Pf=25.0 psf (Lum DOL = 1.15 Plate DOL = 1.15); Is=1.0; Rough Cat B; Partially Exp.; Ce=1.0; Cs=1.00; Ct=1.10
- 4) Unbalanced snow loads have been considered for this design.
- 5) This truss has been designed for greater of min roof live load of 16.0 psf or 1.00 times flat roof load of 25.0 psf on overhangs non-concurrent with other live loads.
- 6) All plates are 2x4 (||) MT20 unless otherwise indicated.
- 7) Gable requires continuous bottom chord bearing.
- 8) Truss to be fully sheathed from one face or securely braced against lateral movement (i.e. diagonal web).
- 9) Gable studs spaced at 2-0-0 oc.
- 10) This truss has been designed for a 10.0 psf bottom chord live load nonconcurrent with any other live loads.
- 11) * This truss has been designed for a live load of 20.0psf on the bottom chord in all areas where a rectangle 3-06-00 tall by 2-00-00 wide will fit between the bottom chord and any other members.
- 12) Provide mechanical connection (by others) of truss to bearing plate capable of withstanding 62 lb uplift at joint 46, 54 lb uplift at joint 25, 53 lb uplift at joint 37, 63 lb uplift at joint 38, 57 lb uplift at joint 39, 59 lb uplift at joint 40, 59 lb uplift at joint 41, 58 lb uplift at joint 42, 61 lb uplift at joint 43, 47 lb uplift at joint 44, 170 lb uplift at joint 45, 47 lb uplift at joint 34, 64 lb uplift at joint 33, 57 lb uplift at joint 32, 59 lb uplift at joint 31, 58 lb uplift at joint 30, 58 lb uplift at joint 29, 61 lb uplift at joint 28, 49 lb uplift at joint 27 and 155 lb uplift at joint 26.
- 13) Graphical purlin representation does not depict the size or the orientation of the purlin along the top and/or bottom chord.

LOAD CASE(S) Standard

WARNING - Verify design parameters and READ NOTES ON THIS AND INCLUDED MITEK REFERENCE PAGE MII-7473 rev. 1/2/2023 BEFORE USE.

Design valid for use only with MiTek® connectors. This design is based only upon parameters shown, and is for an individual building component, not a truss system. Before use, the building designer must verify the applicability of design parameters and properly incorporate this design into the overall building design. Bracing indicated is to prevent buckling of individual truss web and/or chord members only. Additional temporary and permanent bracing is always required for stability and to prevent collapse with possible personal injury and property damage. For general guidance regarding the fabrication, storage, delivery, erection and bracing of trusses and truss systems, see **ANSI/TPI1 Quality Criteria and DSB-22** available from Truss Plate Institute (www.tpinst.org) and **BCSI Building Component Safety Information** available from the Structural Building Component Association (www.sbcsccomponents.com)

MiTek®

400 Sunrise Ave., Suite 270
Roseville, CA 95661
916.755.3571 / MiTek-US.com

Job J1183948	Truss B02	Truss Type Common	Qty 8	Ply 1	NW Eastside Builders LLC Job Reference (optional)	R90572895
-----------------	--------------	----------------------	----------	----------	--	-----------

The Truss Company (Sumner, WA), Sumner, WA - 98390,

Run: 25.30 S Sep 17 2025 Print: 25.3.0 S Sep 17 2025 MiTek Industries, Inc. Thu Oct 02 17:24:49
ID:P7qCwdsJYPsprQu4KciMJZz9U_a-RfC?PsB70Hq3NSgPqnL8w3ulTXbGKWrCDoi7J4zJC?

Page: 1

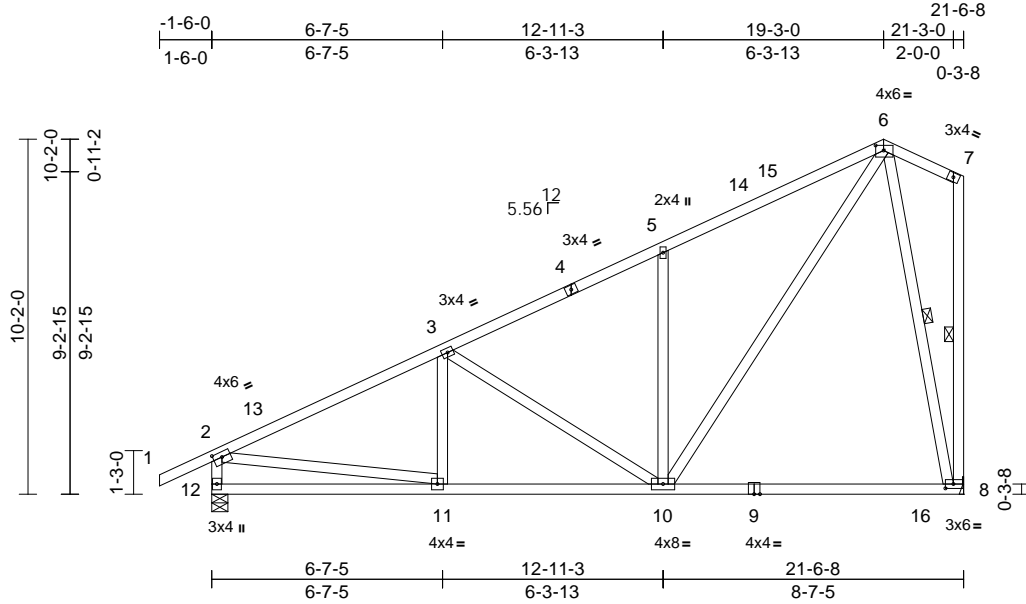

Scale = 1:66

Plate Offsets (X, Y): [2:0-3-0,0-1-12], [6:0-2-12,0-1-12], [8:0-2-12,0-1-8]

Loading	(psf)	Spacing	2-0-0	CSI	DEFL	in	(loc)	l/defl	L/d	PLATES	GRIP	
TCLL (Roof Snow = 25.0)	25.0	Plate Grip DOL	1.15	TC	0.47	Vert(LL)	-0.27	8-10	>944	240	MT20	185/148
TCDL	8.0	Lumber DOL	1.15	BC	0.57	Vert(CT)	-0.38	8-10	>675	180		
BCLL	0.0*	Rep Stress Incr	YES	WB	0.63	Horz(CT)	0.01	8	n/a	n/a		
BCDL	7.0	Code	IRC2021/TPI2014	Matrix-MS								
											Weight: 129 lb	FT = 20%

LUMBER

TOP CHORD 2x4 HF-N No.1/No.2
 BOT CHORD 2x4 HF-N No.1/No.2
 WEBS 2x4 DF Stud *Except* 10-3,10-6,8-7,8-6:2x4 HF-N No.1/No.2

BRACING

TOP CHORD Structural wood sheathing directly applied or 5-3-6 oc purlins, except end verticals.
 BOT CHORD Rigid ceiling directly applied or 10-0-0 oc bracing.
 WEBS 1 Row at midpt 7-8, 6-8

REACTIONS

(size) 8= Mechanical, 12=0-5-8
 Max Horiz 12=254 (LC 9)
 Max Uplift 8=-176 (LC 12), 12=-162 (LC 12)
 Max Grav 8=953 (LC 22), 12=998 (LC 25)

FORCES

(lb) - Maximum Compression/Maximum Tension
 TOP CHORD 1-2=0/46, 2-3=-1286/228, 3-5=-937/219, 5-6=-944/330, 6-7=-163/204, 2-12=-930/235, 7-8=-121/143
 BOT CHORD 11-12=-268/377, 10-11=-218/1080, 8-10=-87/182
 WEBS 3-11=-52/124, 3-10=-405/151, 5-10=-482/215, 6-10=-280/1048, 2-11=-90/922, 6-8=-833/157

NOTES

1) Wind: ASCE 7-16; Vult=110mph (3-second gust)
 Vasd=87mph; TCDL=4.8psf; BCDL=4.2psf; h=25ft; Cat. II; Exp B; Partially Enclosed; MWFRS (envelope) exterior zone and C-C Exterior(2E) -1-6-0 to 1-6-0, Interior (1) 1-6-0 to 16-3-0, Exterior(2R) 16-3-0 to 19-3-0, Exterior(2E) 19-3-0 to 21-4-12 zone; cantilever left and right exposed; end vertical left and right exposed; C-C for members and forces & MWFRS for reactions shown; Lumber DOL=1.60 plate grip DOL=1.60

- TCLL: ASCE 7-16; Pf=25.0 psf (Lum DOL = 1.15 Plate DOL = 1.15); Is=1.0; Rough Cat B; Partially Exp.; Ce=1.0; Cs=1.00; Ct=1.10
- Unbalanced snow loads have been considered for this design.
- This truss has been designed for greater of min roof live load of 16.0 psf or 1.00 times flat roof load of 25.0 psf on overhangs non-concurrent with other live loads.
- This truss has been designed for a 10.0 psf bottom chord live load nonconcurrent with any other live loads.
- * This truss has been designed for a live load of 20.0psf on the bottom chord in all areas where a rectangle 3-06-00 tall by 2-00-00 wide will fit between the bottom chord and any other members, with BCDL = 7.0psf.
- Refer to girder(s) for truss to truss connections.
- Provide mechanical connection (by others) of truss to bearing plate capable of withstanding 162 lb uplift at joint 12 and 176 lb uplift at joint 8.

LOAD CASE(S) Standard



October 3, 2025

WARNING - Verify design parameters and READ NOTES ON THIS AND INCLUDED MITEK REFERENCE PAGE MII-7473 rev. 1/2/2023 BEFORE USE.

Design valid for use only with MiTek® connectors. This design is based only upon parameters shown, and is for an individual building component, not a truss system. Before use, the building designer must verify the applicability of design parameters and properly incorporate this design into the overall building design. Bracing indicated is to prevent buckling of individual truss web and/or chord members only. Additional temporary and permanent bracing is always required for stability and to prevent collapse with possible personal injury and property damage. For general guidance regarding the fabrication, storage, delivery, erection and bracing of trusses and truss systems, see ANSI/TPI1 Quality Criteria and DSB-22 available from Truss Plate Institute (www.tpinst.org) and BCSI Building Component Safety Information available from the Structural Building Component Association (www.sbcscomponents.com)

MiTek®

400 Sunrise Ave., Suite 270
 Roseville, CA 95661
 916.755.3571 / MiTek-US.com

Job J1183948	Truss B03	Truss Type Common Girder	Qty 1	Ply 2	NW Eastside Builders LLC Job Reference (optional)	R90572896
-----------------	--------------	-----------------------------	----------	----------	--	-----------

The Truss Company (Sumner, WA), Sumner, WA - 98390,

Run: 25.30 S Sep 17 2025 Print: 25.30 S Sep 17 2025 MiTek Industries, Inc. Thu Oct 02 17:24:49
ID:lu4jil?vqbdMEK2BrZSnlTPz9U_W-RfC?PsB70Hq3NSgPqnL8w3ulTXhGKWRcDoi7J4zJC?f

Page: 1

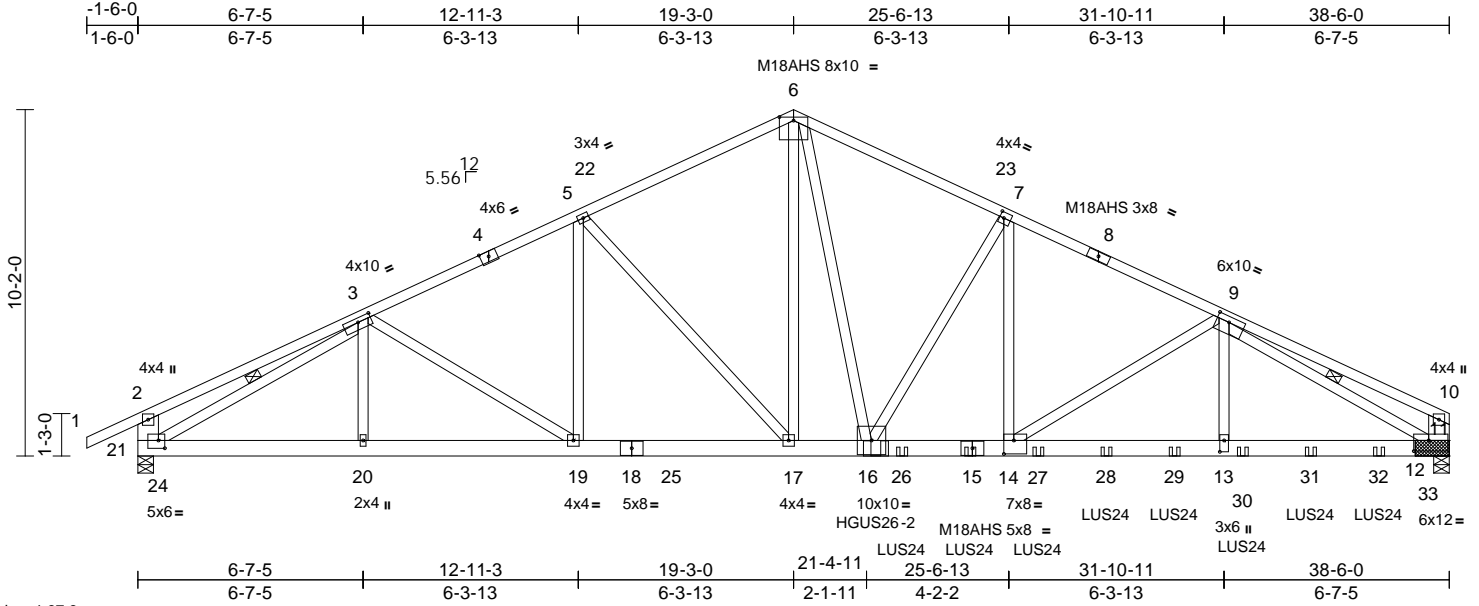

Scale = 1:67.6

Plate Offsets (X, Y): [3:0-4-11,0-1-8], [6:0-5-0,0-1-4], [7:0-1-8,0-2-0], [9:0-4-7,0-2-0], [11:0-5-4,0-3-12], [13:0-4-0,0-1-8], [14:0-3-8,0-4-12], [21:0-2-4,0-2-12]

Loading	(psf)	Spacing	2-0-0	CSI	DEFL	in	(loc)	l/defl	L/d	PLATES	GRIP
TCLL (Roof Snow = 25.0)	25.0	Plate Grip DOL	1.15	TC	0.79	Vert(LL)	-0.28	13-14	>999	240	MT20 185/148
TCDL	8.0	Lumber DOL	1.15	BC	0.84	Vert(CT)	-0.45	13-14	>999	180	M18AHS 145/140
BCLL	0.0*	Rep Stress Incr	NO	WB	0.87	Horz(CT)	0.13	11	n/a	n/a	
BCDL	7.0	Code	IRC2021/TPI2014	Matrix-MS							
											Weight: 514 lb FT = 20%

LUMBER	TOP CHORD	BOT CHORD	WEBS	BRACING	TOP CHORD	BOT CHORD	WEBS	REACTIONS	FORCES	TOP CHORD	BOT CHORD	WEBS
TOP CHORD	2x4 DF 2400F 2.0E *Except* 1-4:2x4 HF-N No.1/No.2, 8-10:2x4 DF 1800F 1.6E or 2x4 DF No.1&Btr or 2x4 DF-N 1800F 1.6E	2x6 DF SS	2x4 HF-N No.1/No.2 *Except* 21-2,11-10:2x8 DF SS, 21-3,11-9:2x4 DF 1800F 1.6E or 2x4 DF No.1&Btr or 2x4 DF-N 1800F 1.6E, 20-3,19-5,14-7,13-9:2x4 DF Stud	TOP CHORD Structural wood sheathing directly applied or 3-6-13 oc purlins, except end verticals. BOT CHORD Rigid ceiling directly applied or 10-0-0 oc bracing. WEBS 1 Row at midpt 3-21, 9-11	TOP CHORD	TOP CHORD	TOP CHORD	(size) 11=(0-5-8 + bearing block), (req. 0-6-10), 21=0-5-8 Max Horiz 21=97 (LC 14) Max Uplift 11=-1394 (LC 11), 21=-847 (LC 10) Max Grav 11=8035 (LC 21), 21=4893 (LC 20)	(lb) - Maximum Compression/Maximum Tension TOP CHORD 1-2=0/50, 2-3=-1127/286, 3-5=-8780/1557, 5-6=-8693/1604, 6-7=-10397/1915, 7-9=-11942/2130, 9-10=-1990/404, 2-21=-783/222, 10-11=-1031/241 BOT CHORD 20-21=-1283/7286, 19-20=-1284/7286, 17-19=-1333/7926, 16-17=-1255/7823, 14-16=-1774/10768, 13-14=-1955/11458, 11-13=-1956/11468 WEBS 3-21=-7446/1188, 3-20=-68/128, 3-19=-146/871, 5-19=-427/145, 5-17=-253/446, 6-17=-126/762, 7-14=-421/2687, 9-14=-973/213, 9-13=-265/2044, 9-11=-11493/1942, 6-16=-1357/7115, 7-16=-2982/580	1) 2-ply truss to be connected together with 10d (0.131"x3") nails as follows: Top chords connected as follows: 2x4 - 1 row at 0-6-0 oc, 2x8 - 2 rows staggered at 0-9-0 oc. Bottom chords connected as follows: 2x6 - 2 rows staggered at 0-2-0 oc. Web connected as follows: 2x4 - 1 row at 0-9-0 oc. 2) All loads are considered equally applied to all plies, except if noted as front (F) or back (B) face in the LOAD CASE(S) section. Ply to ply connections have been provided to distribute only loads noted as (F) or (B), unless otherwise indicated. 3) 2x6 DF SS bearing block 12" long at jt. 11 attached to each face with 3 rows of 10d (0.131"x3") nails spaced 3" o.c. 12 Total fasteners per block. Bearing is assumed to be HF Stud. 4) Wind: ASCE 7-16; Vult=110mph (3-second gust) Vasd=87mph; TCCL=4.8psf; BCDL=4.2psf; h=25ft; Cat. II; Exp B; Partially Enclosed; MWFRS (envelope) exterior zone; cantilever left and right exposed; end vertical left and right exposed; Lumber DOL=1.60 plate grip DOL=1.60 5) TCLL: ASCE 7-16; Pf=25.0 psf (Lum DOL = 1.15 Plate DOL = 1.15); Is=1.0; Rough Cat B; Partially Exp.; Ce=1.0; Cs=1.00; Ct=1.10 6) Unbalanced snow loads have been considered for this design. 7) This truss has been designed for greater of min roof live load of 16.0 psf or 1.00 times flat roof load of 25.0 psf on overhangs non-concurrent with other live loads. 8) All plates are MT20 plates unless otherwise indicated. 9) This truss has been designed for a 10.0 psf bottom chord live load nonconcurrent with any other live loads. 10) * This truss has been designed for a live load of 20.0psf on the bottom chord in all areas where a rectangle 3-06-00 tall by 2-00-00 wide will fit between the bottom chord and any other members, with BCDL = 7.0psf.	11) Provide mechanical connection (by others) of truss to bearing plate capable of withstanding 1394 lb uplift at joint 11 and 847 lb uplift at joint 21. 12) Use Simpson Strong-Tie HGUS26-2 (20-16d Girder, 8-16d Truss) or equivalent at 21-8-0 from the left end to connect truss(es) to front face of bottom chord. 13) Use Simpson Strong-Tie LUS24 (4-10d Girder, 2-10d Truss) or equivalent spaced at 2-0-0 oc max. starting at 22-5-4 from the left end to 36-5-4 to connect truss(es) to front face of bottom chord. 14) Fill all nail holes where hanger is in contact with lumber.	

LOAD CASE(S) Standard
1) Dead + Snow (balanced): Lumber Increase=1.15, Plate Increase=1.15
Uniform Loads (lb/ft)
Vert: 1-2=-66, 2-6=-66, 6-10=-66, 11-21=-14
Concentrated Loads (lb)
Vert: 15=-661 (F), 16=-4113 (F), 26=-661 (F), 27=-661 (F), 28=-661 (F), 29=-661 (F), 30=-661 (F), 31=-661 (F), 32=-661 (F)



October 3, 2025

WARNING - Verify design parameters and READ NOTES ON THIS AND INCLUDED MITEK REFERENCE PAGE MII-7473 rev. 1/2/2023 BEFORE USE.

Design valid for use only with MiTek® connectors. This design is based only upon parameters shown, and is for an individual building component, not a truss system. Before use, the building designer must verify the applicability of design parameters and properly incorporate this design into the overall building design. Bracing indicated is to prevent buckling of individual truss web and/or chord members only. Additional temporary and permanent bracing is always required for stability and to prevent collapse with possible personal injury and property damage. For general guidance regarding the fabrication, storage, delivery, erection and bracing of trusses and truss systems, see **ANSI/TPI1 Quality Criteria and DSB-22** available from Truss Plate Institute (www.tpinst.org) and **BCSI Building Component Safety Information** available from the Structural Building Component Association (www.sbcsccomponents.com)

MiTek®

400 Sunrise Ave., Suite 270
Roseville, CA 95661
916.755.3571 / MiTek-US.com

Job J1183948	Truss B04	Truss Type Common	Qty 3	Ply 1	NW Eastside Builders LLC Job Reference (optional)	R90572897
-----------------	--------------	----------------------	----------	----------	--	-----------

The Truss Company (Sumner, WA), Sumner, WA - 98390,

Run: 25.30 S Sep 17 2025 Print: 25.3.0 S Sep 17 2025 MiTek Industries, Inc. Thu Oct 02 17:24:49
ID:LLhYzlaKME7FgfH3QEhnPkz980w-RfC?PsB70Hq3NSgPqnL8w3ulTXbGKWrCDoi7J4zJC?f

Page: 1

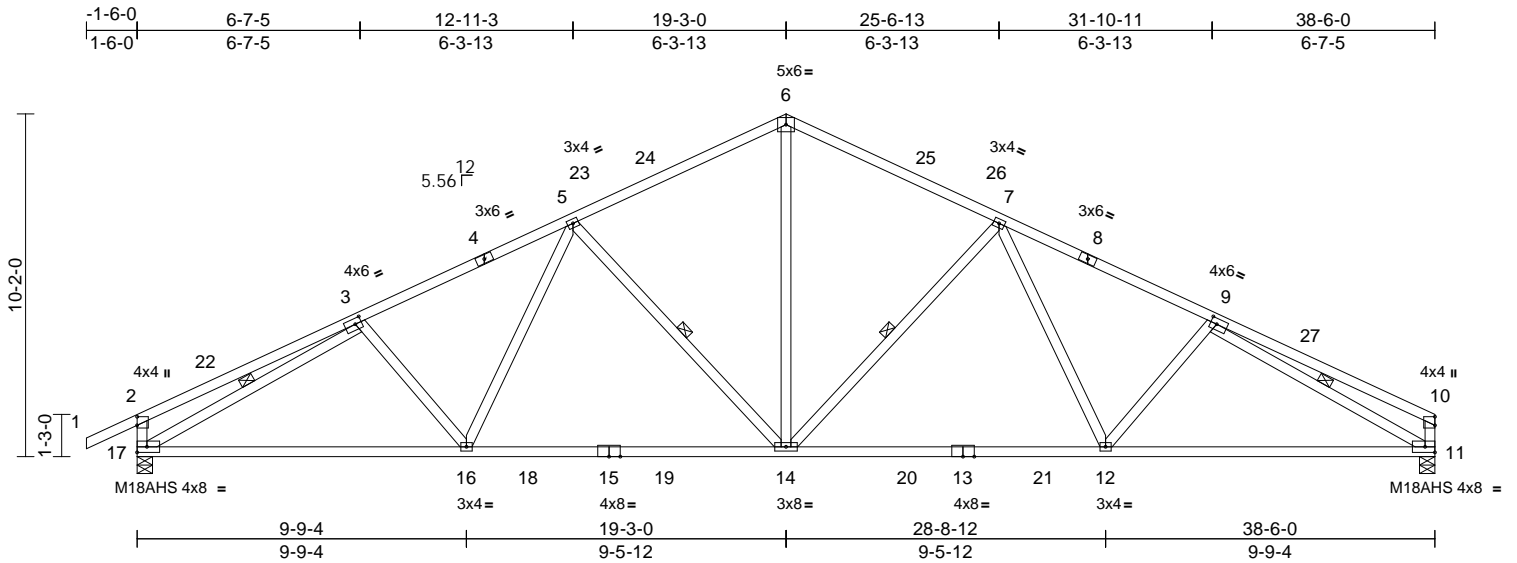

Scale = 1:68.3

Plate Offsets (X, Y): [2:0-3-1,Edge], [3:0-2-4,0-2-0], [9:0-2-4,0-2-0]

Loading	(psf)	Spacing	2-0-0	CSI	DEFL	in	(loc)	l/defl	L/d	PLATES	GRIP	
TCLL	25.0	Plate Grip DOL	1.15	TC	0.70	Vert(LL)	-0.30	12-14	>999	240	MT20	185/148
(Roof Snow = 25.0)		Lumber DOL	1.15	BC	0.89	Vert(CT)	-0.45	12-14	>999	180	M18AHS	145/140
TCDL	8.0	Rep Stress Incr	YES	WB	0.59	Horz(CT)	0.12	11	n/a	n/a		
BCLL	0.0*	Code	IRC2021/TPI2014	Matrix-MS								
BCDL	7.0											
											Weight: 190 lb	FT = 20%

LUMBER

TOP CHORD 2x4 HF-N No.1/No.2
 BOT CHORD 2x4 HF-N No.1/No.2
 WEBS 2x4 HF-N No.1/No.2 *Except*
 12-9,16-3,17-2,11-10:2x4 DF Stud

BRACING

TOP CHORD Structural wood sheathing directly applied or
 3-3-12 oc purlins, except end verticals.
 BOT CHORD Rigid ceiling directly applied or 9-10-3 oc
 bracing.
 WEBS 1 Row at midpt 7-14, 5-14, 3-17, 9-11

REACTIONS

(size) 11=0-5-8, 17=0-5-8
 Max Horiz 17=95 (LC 16)
 Max Uplift 11=238 (LC 13), 17=260 (LC 12)
 Max Grav 11=1656 (LC 23), 17=1736 (LC 22)

FORCES

(lb) - Maximum Compression/Maximum
 Tension
 TOP CHORD 2-17=-444/159, 10-11=-302/105, 1-2=0/46,
 2-3=-396/130, 3-5=-2524/422,
 5-6=-1906/403, 6-7=-1905/403,
 7-9=-2534/432, 9-10=-356/107
 BOT CHORD 16-17=-375/2262, 14-16=-262/2086,
 12-14=-210/2062, 11-12=-301/2234
 WEBS 6-14=-175/1225, 7-14=-720/230,
 7-12=-38/395, 9-12=-127/158,
 5-14=-708/230, 5-16=-35/382,
 3-16=-107/154, 3-17=-2295/324,
 9-11=-2350/331

NOTES

- 1) Wind: ASCE 7-16; Vult=110mph (3-second gust)
 Vasd=87mph; TCDL=4.8psf; BCDL=4.2psf; h=25ft; Cat.
 II; Exp B; Partially Enclosed; MWFRS (envelope)
 exterior zone and C-C Exterior(2E) -1-6-0 to 2-4-3,
 Interior (1) 2-4-3 to 15-4-13, Exterior(2R) 15-4-13 to
 23-1-3, Interior (1) 23-1-3 to 34-6-1, Exterior(2E) 34-6-1
 to 38-4-4 zone; cantilever left and right exposed ; end
 vertical left and right exposed;C-C for members and
 forces & MWFRS for reactions shown; Lumber
 DOL=1.60 plate grip DOL=1.60
- 2) TCLL: ASCE 7-16; Pf=25.0 psf (Lum DOL = 1.15 Plate
 DOL = 1.15); Is=1.0; Rough Cat B; Partially Exp.;
 Ce=1.0; Cs=1.00; Ct=1.10
- 3) Unbalanced snow loads have been considered for this
 design.
- 4) This truss has been designed for greater of min roof live
 load of 16.0 psf or 1.00 times flat roof load of 25.0 psf on
 overhangs non-concurrent with other live loads.
- 5) All plates are MT20 plates unless otherwise indicated.
- 6) This truss has been designed for a 10.0 psf bottom
 chord live load nonconcurrent with any other live loads.
- 7) * This truss has been designed for a live load of 20.0psf
 on the bottom chord in all areas where a rectangle
 3-06-00 tall by 2-00-00 wide will fit between the bottom
 chord and any other members, with BCDL = 7.0psf.
- 8) Provide mechanical connection (by others) of truss to
 bearing plate capable of withstanding 260 lb uplift at joint
 17 and 238 lb uplift at joint 11.

LOAD CASE(S) Standard



October 3, 2025

WARNING - Verify design parameters and READ NOTES ON THIS AND INCLUDED MITEK REFERENCE PAGE MII-7473 rev. 1/2/2023 BEFORE USE.

Design valid for use only with MiTek® connectors. This design is based only upon parameters shown, and is for an individual building component, not a truss system. Before use, the building designer must verify the applicability of the design parameters and properly incorporate this design into the overall building design. Bracing indicated is to prevent buckling of individual truss web and/or chord members only. Additional temporary and permanent bracing is always required for stability and to prevent collapse with possible personal injury and property damage. For general guidance regarding the fabrication, storage, delivery, erection and bracing of trusses and truss systems, see **ANSI/TPI1 Quality Criteria and DSB-22** available from Truss Plate Institute (www.tpinst.org) and **BCSI Building Component Safety Information** available from the Structural Building Component Association (www.sbcsccomponents.com)

MiTek®

400 Sunrise Ave., Suite 270
 Roseville, CA 95661
 916.755.3571 / MiTek-US.com

Job J1183948	Truss B05	Truss Type Common	Qty 4	Ply 1	NW Eastside Builders LLC Job Reference (optional)	R90572898
-----------------	--------------	----------------------	----------	----------	--	-----------

The Truss Company (Sumner, WA), Sumner, WA - 98390,

Run: 25.30 S Sep 17 2025 Print: 25.3.0 S Sep 17 2025 MiTek Industries, Inc. Thu Oct 02 17:24:49
ID:qXFxA5by7XF6lpsF_xC0yzz980v-RfC?PsB70Hq3NSgPqnL8w3ulTXbGKWRcDoi7J4zJC?f

Page: 1

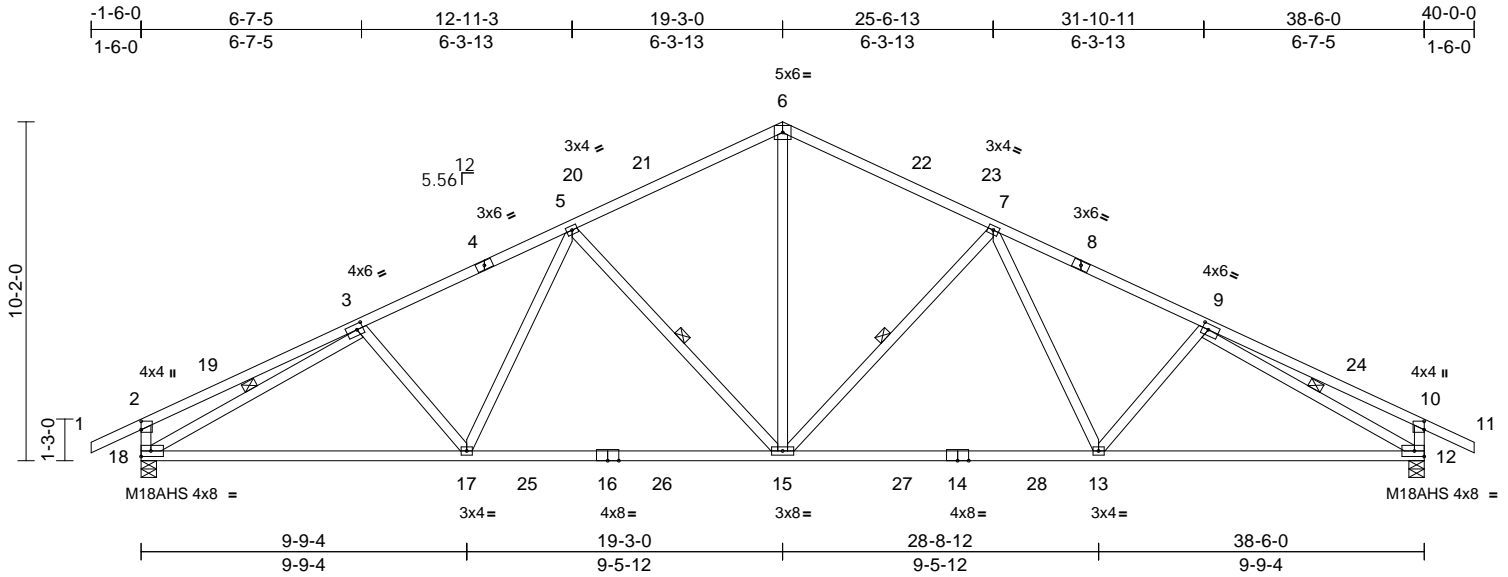

Scale = 1:69.1

Plate Offsets (X, Y): [2:0-3-1,Edge], [3:0-2-4,0-2-0], [9:0-2-4,0-2-0], [10:0-3-1,Edge]

Loading	(psf)	Spacing	2-0-0	CSI	DEFL	in	(loc)	l/defl	L/d	PLATES	GRIP	
TCLL (Roof Snow = 25.0)	25.0	Plate Grip DOL	1.15	TC	0.68	Vert(LL)	-0.30	13-15	>999	240	MT20	185/148
TCDL	8.0	Lumber DOL	1.15	BC	0.88	Vert(CT)	-0.45	13-15	>999	180	M18AHS	145/140
BCLL	0.0*	Rep Stress Incr	YES	WB	0.58	Horz(CT)	0.12	12	n/a	n/a		
BCDL	7.0	Code	IRC2021/TPI2014	Matrix-MS								
											Weight: 192 lb	FT = 20%

LUMBER

TOP CHORD 2x4 HF-N No.1/No.2
 BOT CHORD 2x4 HF-N No.1/No.2
 WEBS 2x4 HF-N No.1/No.2 *Except*
 13-9,17-3,18-2,12-10:2x4 DF Stud

BRACING

TOP CHORD Structural wood sheathing directly applied or
 3-5-2 oc purlins, except end verticals.
 BOT CHORD Rigid ceiling directly applied or 9-11-7 oc
 bracing.
 WEBS 1 Row at midpt 7-15, 5-15, 3-18, 9-12

REACTIONS

(size) 12=0-5-8, 18=0-5-8
 Max Horiz 18=87 (LC 13)
 Max Uplift 12=260 (LC 13), 18=260 (LC 12)
 Max Grav 12=1735 (LC 23), 18=1735 (LC 22)

FORCES

(lb) - Maximum Compression/Maximum
 Tension
 TOP CHORD 2-18=-444/159, 10-12=-444/169, 1-2=0/46,
 2-3=-396/130, 3-5=-2520/419,
 5-6=-1902/400, 6-7=-1902/400,
 7-9=-2521/421, 9-10=-396/129, 10-11=0/46
 BOT CHORD 17-18=-367/2266, 15-17=-254/2090,
 13-15=-177/2065, 12-13=-280/2220
 WEBS 6-15=-173/1223, 7-15=-715/230,
 7-13=-35/383, 9-13=-108/154,
 5-15=-715/230, 5-17=-35/382,
 3-17=-108/154, 3-18=-2292/322,
 9-12=-2292/301

NOTES

- 1) Wind: ASCE 7-16; Vult=110mph (3-second gust)
 Vasd=87mph; TCDL=4.8psf; BCDL=4.2psf; h=25ft; Cat.
 II; Exp B; Partially Enclosed; MWFRS (envelope)
 exterior zone and C-C Exterior(2E) -1-6-0 to 2-4-3,
 Interior (1) 2-4-3 to 15-4-13, Exterior(2R) 15-4-13 to
 23-1-3, Interior (1) 23-1-3 to 36-1-13, Exterior(2E)
 36-1-13 to 40-0-0 zone; cantilever left and right
 exposed; end vertical left and right exposed; C-C for
 members and forces & MWFRS for reactions shown;
 Lumber DOL=1.60 plate grip DOL=1.60
- 2) TCLL: ASCE 7-16; Pf=25.0 psf (Lum DOL = 1.15 Plate
 DOL = 1.15); Is=1.0; Rough Cat B; Partially Exp.;
 Ce=1.0; Cs=1.00; Ct=1.10
- 3) Unbalanced snow loads have been considered for this
 design.
- 4) This truss has been designed for greater of min roof live
 load of 16.0 psf or 1.00 times flat roof load of 25.0 psf on
 overhangs non-concurrent with other live loads.
- 5) All plates are MT20 plates unless otherwise indicated.
- 6) This truss has been designed for a 10.0 psf bottom
 chord live load nonconcurrent with any other live loads.
- 7) * This truss has been designed for a live load of 20.0psf
 on the bottom chord in all areas where a rectangle
 3-06-00 tall by 2-00-00 wide will fit between the bottom
 chord and any other members, with BCDL = 7.0psf.
- 8) Provide mechanical connection (by others) of truss to
 bearing plate capable of withstanding 260 lb uplift at joint
 18 and 260 lb uplift at joint 12.

LOAD CASE(S) Standard



October 3, 2025

WARNING - Verify design parameters and READ NOTES ON THIS AND INCLUDED MITEK REFERENCE PAGE MII-7473 rev. 1/2/2023 BEFORE USE.

Design valid for use only with MiTek® connectors. This design is based only upon parameters shown, and is for an individual building component, not a truss system. Before use, the building designer must verify the applicability of the design parameters and properly incorporate this design into the overall building design. Bracing indicated is to prevent buckling of individual truss web and/or chord members only. Additional temporary and permanent bracing is always required for stability and to prevent collapse with possible personal injury and property damage. For general guidance regarding the fabrication, storage, delivery, erection and bracing of trusses and truss systems, see **ANSI/TPI1 Quality Criteria and DSB-22** available from Truss Plate Institute (www.tpin.org) and **BCSI Building Component Safety Information** available from the Structural Building Component Association (www.sbcsccomponents.com)

MiTek®

400 Sunrise Ave., Suite 270
 Roseville, CA 95661
 916.755.3571 / MiTek-US.com

Job J1183948	Truss B06	Truss Type Common	Qty 1	Ply 1	NW Eastside Builders LLC Job Reference (optional)	R90572899
-----------------	--------------	----------------------	----------	----------	--	-----------

The Truss Company (Sumner, WA), Sumner, WA - 98390,

Run: 25.30 S Sep 17 2025 Print: 25.3.0 S Sep 17 2025 MiTek Industries, Inc. Thu Oct 02 17:24:49
ID:qXFxA5by7XF6lpsF_xC0yyz980v-RfC?PsB70Hq3NSgPqnL8w3lTXbGKWRCDoi7J4zJC?f

Page: 1

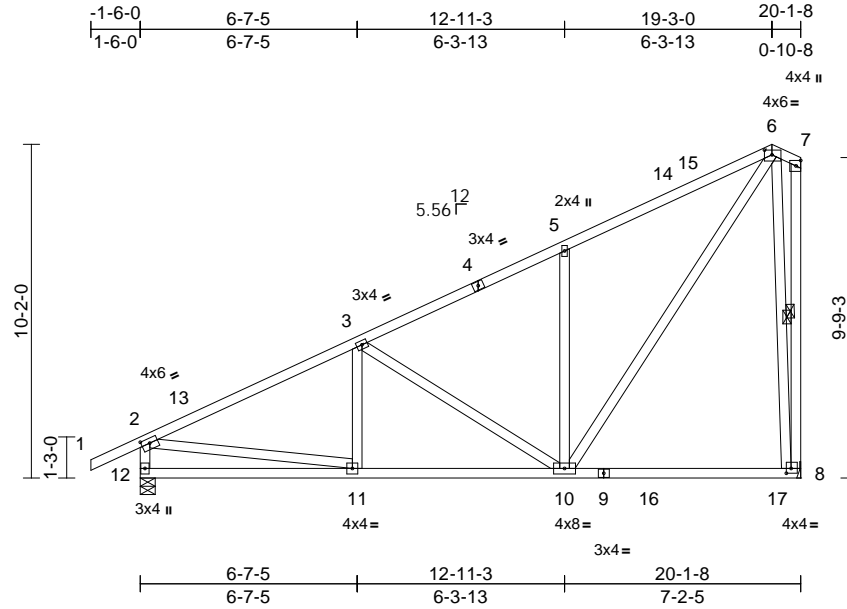

Scale = 1:70.2

Plate Offsets (X, Y): [2:0-3-0,0-1-12], [6:0-2-12,0-1-12], [8:0-1-12,0-1-12]

Loading	(psf)	Spacing	2-0-0	CSI	DEFL	in	(loc)	l/defl	L/d	PLATES	GRIP	
TCLL (Roof Snow = 25.0)	25.0	Plate Grip DOL	1.15	TC	0.45	Vert(LL)	-0.13	8-10	>999	240	MT20	185/148
TCDL	8.0	Lumber DOL	1.15	BC	0.44	Vert(CT)	-0.18	8-10	>999	180		
BCLL	0.0*	Rep Stress Incr	YES	WB	0.66	Horz(CT)	0.01	8	n/a	n/a		
BCDL	7.0	Code	IRC2021/TPI2014	Matrix-MS								
											Weight: 126 lb	FT = 20%

LUMBER

TOP CHORD 2x4 HF-N No.1/No.2
 BOT CHORD 2x4 HF-N No.1/No.2
 WEBS 2x4 DF Stud *Except* 8-7,10-3,10-6,8-6:2x4 HF-N No.1/No.2

BRACING

TOP CHORD Structural wood sheathing directly applied or 5-5-15 oc purlins, except end verticals.
 BOT CHORD Rigid ceiling directly applied or 10-0-0 oc bracing.
 WEBS 1 Row at midpt 7-8, 6-8

REACTIONS

(size) 8= Mechanical, 12=0-5-8
 Max Horiz 12=269 (LC 9)
 Max Uplift 8=-182 (LC 12), 12=-149 (LC 12)
 Max Grav 8=887 (LC 22), 12=946 (LC 25)

FORCES

(lb) - Maximum Compression/Maximum Tension
 TOP CHORD 1-2=0/46, 2-3=-1199/214, 3-5=-817/202, 5-6=-824/314, 6-7=-210/247, 2-12=-864/229, 7-8=-216/230
 BOT CHORD 11-12=-283/395, 10-11=-198/981, 8-10=-118/153
 WEBS 2-11=-74/846, 3-11=-31/145, 3-10=-439/152, 5-10=-453/212, 6-10=-292/1017, 6-8=-849/206

NOTES

1) Wind: ASCE 7-16; Vult=110mph (3-second gust)
 Vasd=87mph; TCDL=4.8psf; BCDL=4.2psf; h=25ft; Cat. II; Exp B; Partially Enclosed; MWFRS (envelope) exterior zone and C-C Exterior(2E) -1-6-0 to 1-6-0, Interior (1) 1-6-0 to 16-3-0, Exterior(2R) 16-3-0 to 19-3-0, Exterior(2E) 19-3-0 to 19-11-12 zone; cantilever left and right exposed; end vertical left and right exposed; C-C for members and forces & MWFRS for reactions shown; Lumber DOL=1.60 plate grip DOL=1.60

- TCLL: ASCE 7-16; Pf=25.0 psf (Lum DOL = 1.15 Plate DOL = 1.15); Is=1.0; Rough Cat B; Partially Exp.; Ce=1.0; Cs=1.00; Ct=1.10
- Unbalanced snow loads have been considered for this design.
- This truss has been designed for greater of min roof live load of 16.0 psf or 1.00 times flat roof load of 25.0 psf on overhangs non-concurrent with other live loads.
- This truss has been designed for a 10.0 psf bottom chord live load nonconcurrent with any other live loads.
- * This truss has been designed for a live load of 20.0psf on the bottom chord in all areas where a rectangle 3-06-00 tall by 2-00-00 wide will fit between the bottom chord and any other members, with BCDL = 7.0psf.
- Refer to girder(s) for truss to truss connections.
- Provide mechanical connection (by others) of truss to bearing plate capable of withstanding 149 lb uplift at joint 12 and 182 lb uplift at joint 8.

LOAD CASE(S) Standard



October 3, 2025

WARNING - Verify design parameters and READ NOTES ON THIS AND INCLUDED MITEK REFERENCE PAGE MII-7473 rev. 1/2/2023 BEFORE USE.

Design valid for use only with MiTek® connectors. This design is based only upon parameters shown, and is for an individual building component, not a truss system. Before use, the building designer must verify the applicability of design parameters and properly incorporate this design into the overall building design. Bracing indicated is to prevent buckling of individual truss web and/or chord members only. Additional temporary and permanent bracing is always required for stability and to prevent collapse with possible personal injury and property damage. For general guidance regarding the fabrication, storage, delivery, erection and bracing of trusses and truss systems, see **ANSI/TPI1 Quality Criteria and DSB-22** available from Truss Plate Institute (www.tpinst.org) and **BCSI Building Component Safety Information** available from the Structural Building Component Association (www.sbcsccomponents.com)

MiTek®

400 Sunrise Ave., Suite 270
 Roseville, CA 95661
 916.755.3571 / MiTek-US.com

Job J1183948	Truss B07	Truss Type Common	Qty 1	Ply 1	NW Eastside Builders LLC Job Reference (optional)	R90572900
-----------------	--------------	----------------------	----------	----------	--	-----------

The Truss Company (Sumner, WA), Sumner, WA - 98390,

Run: 25.30 S Sep 17 2025 Print: 25.3.0 S Sep 17 2025 MiTek Industries, Inc. Thu Oct 02 17:24:49
ID:ljpJORbaurNzvzRRxfjV9z980u-RfC?PsB70Hq3NSgPqnL8w3uITxBGKWrCDoi7J4zJC?f

Page: 1

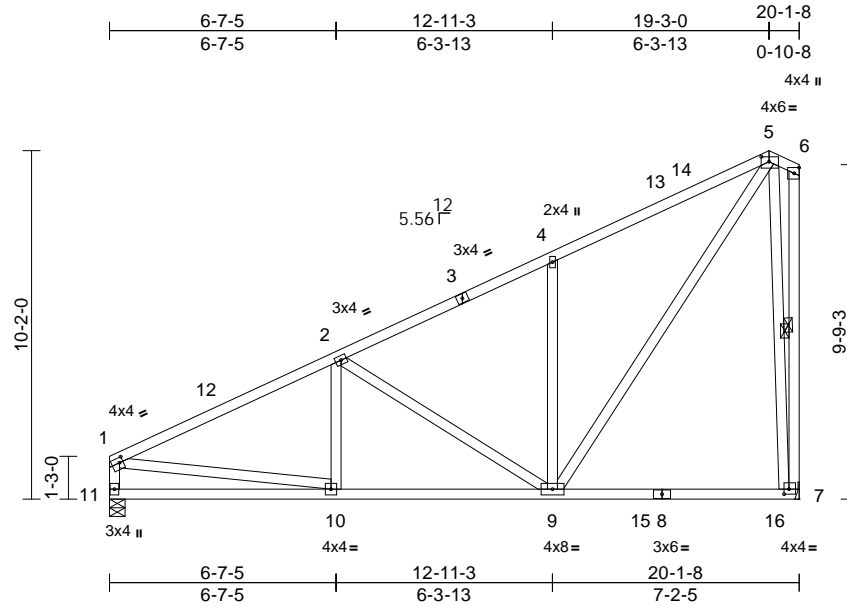

Scale = 1:67.2

Plate Offsets (X, Y): [1:0-1-4,0-1-12], [5:0-2-12,0-1-12], [7:0-1-12,0-1-12]

Loading	(psf)	Spacing	2-0-0	CSI	DEFL	in	(loc)	l/defl	L/d	PLATES	GRIP	
TCLL (Roof Snow = 25.0)	25.0	Plate Grip DOL	1.15	TC	0.45	Vert(LL)	-0.13	7-9	>999	240	MT20	185/148
TCDL	8.0	Lumber DOL	1.15	BC	0.44	Vert(CT)	-0.19	7-9	>999	180		
BCLL	0.0*	Rep Stress Incr	YES	WB	0.66	Horz(CT)	0.01	7	n/a	n/a		
BCDL	7.0	Code	IRC2021/TPI2014	Matrix-MS								
											Weight: 123 lb	FT = 20%

LUMBER

TOP CHORD 2x4 HF-N No.1/No.2
 BOT CHORD 2x4 HF-N No.1/No.2
 WEBS 2x4 DF Stud *Except* 7-6,9-2,9-5,7-5:2x4 HF-N No.1/No.2

BRACING

TOP CHORD Structural wood sheathing directly applied or 5-2-3 oc purlins, except end verticals.
 BOT CHORD Rigid ceiling directly applied or 10-0-0 oc bracing.
 WEBS 1 Row at midpt 6-7, 5-7

REACTIONS

(size) 7= Mechanical, 11=0-5-8
 Max Horiz 11=259 (LC 9)
 Max Uplift 7=-183 (LC 12), 11=-127 (LC 12)
 Max Grav 7=891 (LC 21), 11=868 (LC 24)

FORCES

(lb) - Maximum Compression/Maximum Tension
 TOP CHORD 1-2=-1210/220, 2-4=-821/205, 4-5=-827/315, 5-6=-210/246, 1-11=-776/175, 6-7=-215/229
 BOT CHORD 10-11=-261/365, 9-10=-202/998, 7-9=-118/152
 WEBS 1-10=-100/877, 2-10=-36/143, 2-9=-456/156, 4-9=-446/209, 5-9=-292/1021, 5-7=-856/207

NOTES

- 1) Wind: ASCE 7-16; Vult=110mph (3-second gust) Vasd=87mph; TCDL=4.8psf; BCDL=4.2psf; h=25ft; Cat. II; Exp B; Partially Enclosed; MWFRS (envelope) exterior zone and C-C Exterior(2E) 0-1-12 to 3-1-12, Interior (1) 3-1-12 to 16-3-0, Exterior(2R) 16-3-0 to 19-3-0, Exterior(2E) 19-3-0 to 19-11-12 zone; cantilever left and right exposed; end vertical left and right exposed; C-C for members and forces & MWFRS for reactions shown; Lumber DOL=1.60 plate grip DOL=1.60
- 2) TCLL: ASCE 7-16; Pf=25.0 psf (Lum DOL = 1.15 Plate DOL = 1.15); Is=1.0; Rough Cat B; Partially Exp.; Ce=1.0; Cs=1.00; Ct=1.10

- 3) Unbalanced snow loads have been considered for this design.
- 4) This truss has been designed for a 10.0 psf bottom chord live load nonconcurrent with any other live loads.
- 5) * This truss has been designed for a live load of 20.0psf on the bottom chord in all areas where a rectangle 3-06-00 tall by 2-00-00 wide will fit between the bottom chord and any other members, with BCDL = 7.0psf.
- 6) Refer to girder(s) for truss to truss connections.
- 7) Provide mechanical connection (by others) of truss to bearing plate capable of withstanding 127 lb uplift at joint 11 and 183 lb uplift at joint 7.

LOAD CASE(S) Standard



October 3, 2025

WARNING - Verify design parameters and READ NOTES ON THIS AND INCLUDED MITEK REFERENCE PAGE MII-7473 rev. 1/2/2023 BEFORE USE.

Design valid for use only with MiTek® connectors. This design is based only upon parameters shown, and is for an individual building component, not a truss system. Before use, the building designer must verify the applicability of design parameters and properly incorporate this design into the overall building design. Bracing indicated is to prevent buckling of individual truss web and/or chord members only. Additional temporary and permanent bracing is always required for stability and to prevent collapse with possible personal injury and property damage. For general guidance regarding the fabrication, storage, delivery, erection and bracing of trusses and truss systems, see **ANSI/TPI1 Quality Criteria and DSB-22** available from Truss Plate Institute (www.tpinst.org) and **BCSI Building Component Safety Information** available from the Structural Building Component Association (www.sbcsccomponents.com)

MiTek®

400 Sunrise Ave., Suite 270
 Roseville, CA 95661
 916.755.3571 / MiTek-US.com

Job J1183948	Truss B08	Truss Type Common	Qty 3	Ply 1	NW Eastside Builders LLC Job Reference (optional)	R90572901
-----------------	--------------	----------------------	----------	----------	--	-----------

The Truss Company (Sumner, WA), Sumner, WA - 98390,

Run: 25.30 S Sep 17 2025 Print: 25.3.0 S Sep 17 2025 MiTek Industries, Inc. Thu Oct 02 17:24:49
ID:TaR27OXpl?dpB2_IBOcrFuz981_RfC?PsB70Hq3NSgPqnL8w3ulTXbGKWrCDoi7J4zJC?f

Page: 1

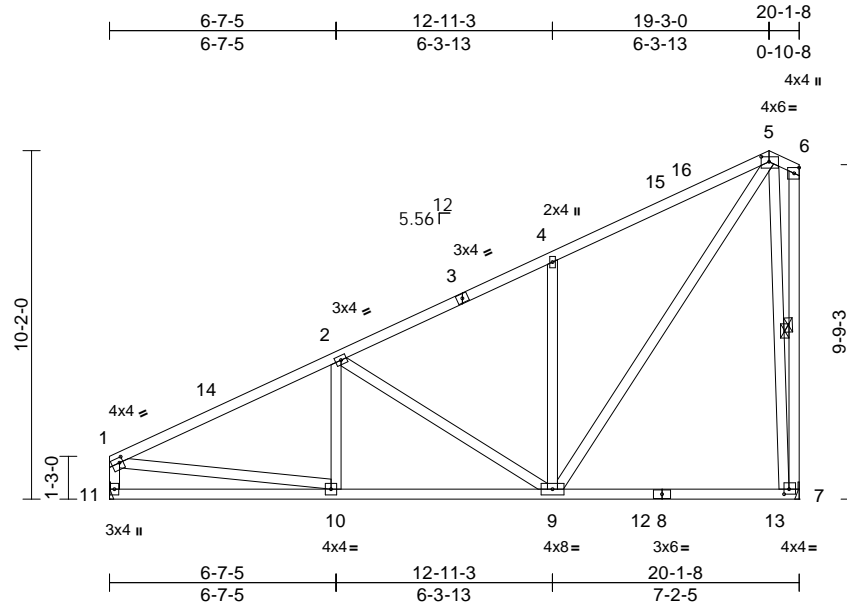

Scale = 1:67.2

Plate Offsets (X, Y): [1:0-1-4,0-1-12], [5:0-2-12,0-1-12], [7:0-1-12,0-1-12]

Loading	(psf)	Spacing	2-0-0	CSI	DEFL	in	(loc)	l/defl	L/d	PLATES	GRIP	
TCLL (Roof Snow = 25.0)	25.0	Plate Grip DOL	1.15	TC	0.45	Vert(LL)	-0.13	7-9	>999	240	MT20	185/148
TCDL	8.0	Lumber DOL	1.15	BC	0.44	Vert(CT)	-0.19	7-9	>999	180		
BCLL	0.0*	Rep Stress Incr	YES	WB	0.66	Horz(CT)	0.01	7	n/a	n/a		
BCDL	7.0	Code	IRC2021/TPI2014	Matrix-MS								
											Weight: 123 lb	FT = 20%

LUMBER

TOP CHORD 2x4 HF-N No.1/No.2
 BOT CHORD 2x4 HF-N No.1/No.2
 WEBS 2x4 DF Stud *Except* 7-6,9-2,9-5,7-5:2x4 HF-N No.1/No.2

BRACING

TOP CHORD Structural wood sheathing directly applied or 5-2-3 oc purlins, except end verticals.
 BOT CHORD Rigid ceiling directly applied or 10-0-0 oc bracing.
 WEBS 1 Row at midpt 6-7, 5-7

REACTIONS (size) 7= Mechanical, 11= Mechanical
 Max Horiz 11=259 (LC 9)
 Max Uplift 7=-183 (LC 12), 11=-127 (LC 12)
 Max Grav 7=891 (LC 21), 11=868 (LC 24)

FORCES

(lb) - Maximum Compression/Maximum Tension
 TOP CHORD 5-6=-210/246, 1-11=-776/175, 6-7=-215/229,
 1-2=-1210/220, 2-4=-821/205, 4-5=-827/315
 BOT CHORD 10-11=-261/365, 9-10=-202/998,
 7-9=-118/152
 WEBS 2-10=-36/143, 2-9=-456/156, 4-9=-446/209,
 5-9=-292/1021, 1-10=-100/877, 5-7=-856/207

NOTES

- 1) Wind: ASCE 7-16; Vult=110mph (3-second gust)
 Vasd=87mph; TCDL=4.8psf; BCDL=4.2psf; h=25ft; Cat. II; Exp B; Partially Enclosed; MWFRS (envelope) exterior zone and C-C Exterior(2E) 0-1-12 to 3-1-12, Interior (1) 3-1-12 to 16-3-0, Exterior(2R) 16-3-0 to 19-3-0, Exterior(2E) 19-3-0 to 19-11-12 zone; cantilever left and right exposed ; end vertical left and right exposed;C-C for members and forces & MWFRS for reactions shown; Lumber DOL=1.60 plate grip DOL=1.60
- 2) TCLL: ASCE 7-16; Pf=25.0 psf (Lum DOL = 1.15 Plate DOL = 1.15); Is=1.0; Rough Cat B; Partially Exp.; Ce=1.0; Cs=1.00; Ct=1.10

- 3) Unbalanced snow loads have been considered for this design.
- 4) This truss has been designed for a 10.0 psf bottom chord live load nonconcurrent with any other live loads.
- 5) * This truss has been designed for a live load of 20.0psf on the bottom chord in all areas where a rectangle 3-06-00 tall by 2-00-00 wide will fit between the bottom chord and any other members, with BCDL = 7.0psf.
- 6) Refer to girder(s) for truss to truss connections.
- 7) Provide mechanical connection (by others) of truss to bearing plate capable of withstanding 183 lb uplift at joint 7 and 127 lb uplift at joint 11.

LOAD CASE(S) Standard



October 3, 2025

WARNING - Verify design parameters and READ NOTES ON THIS AND INCLUDED MITEK REFERENCE PAGE MII-7473 rev. 1/2/2023 BEFORE USE.

Design valid for use only with MiTek® connectors. This design is based only upon parameters shown, and is for an individual building component, not a truss system. Before use, the building designer must verify the applicability of design parameters and properly incorporate this design into the overall building design. Bracing indicated is to prevent buckling of individual truss web and/or chord members only. Additional temporary and permanent bracing is always required for stability and to prevent collapse with possible personal injury and property damage. For general guidance regarding the fabrication, storage, delivery, erection and bracing of trusses and truss systems, see **ANSI/TPI1 Quality Criteria and DSB-22** available from Truss Plate Institute (www.tpinst.org) and **BCSI Building Component Safety Information** available from the Structural Building Component Association (www.sbcsccomponents.com)

MiTek®

400 Sunrise Ave., Suite 270
 Roseville, CA 95661
 916.755.3571 / MiTek-US.com

Job J1183948	Truss B09	Truss Type Common	Qty 5	Ply 1	NW Eastside Builders LLC Job Reference (optional)	R90572902
-----------------	--------------	----------------------	----------	----------	--	-----------

The Truss Company (Sumner, WA), Sumner, WA - 98390,

Run: 25.30 S Sep 17 2025 Print: 25.3.0 S Sep 17 2025 MiTek Industries, Inc. Thu Oct 02 17:24:50
ID:ljpJORbaurNzvzRRxfjFV9z980u-RfC?PsB70Hq3NSgPqnL8w3uITxbGKWrCdoi7J4zJC?f

Page: 1

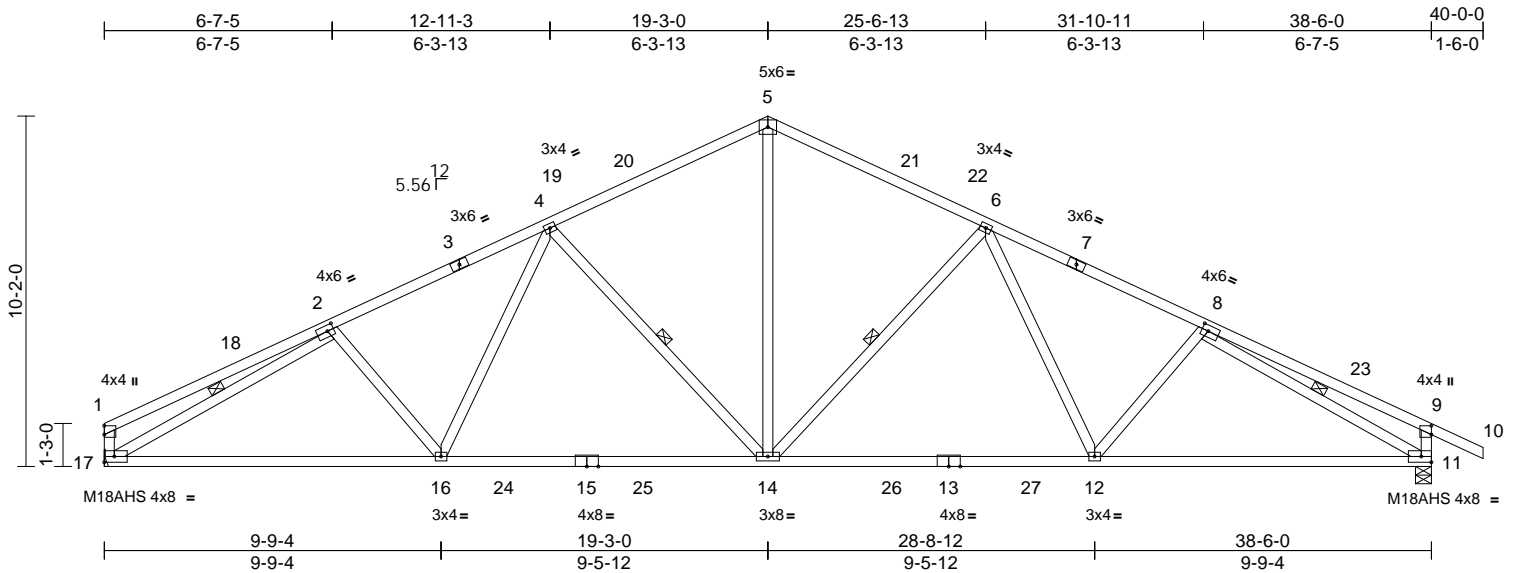

Scale = 1:66.8

Plate Offsets (X, Y): [2:0-2-4,0-2-0], [8:0-2-4,0-2-0], [9:0-3-1,Edge]

Loading	(psf)	Spacing	2-0-0	CSI	DEFL	in	(loc)	l/defl	L/d	PLATES	GRIP	
TCLL (Roof Snow = 25.0)	25.0	Plate Grip DOL	1.15	TC	0.70	Vert(LL)	-0.30	14-16	>999	240	MT20	185/148
TCDL	8.0	Lumber DOL	1.15	BC	0.89	Vert(CT)	-0.45	14-16	>999	180	M18AHS	145/140
BCLL	0.0*	Rep Stress Incr	YES	WB	0.59	Horz(CT)	0.12	11	n/a	n/a		
BCDL	7.0	Code	IRC2021/TPI2014	Matrix-MS								
											Weight: 190 lb	FT = 20%

LUMBER

TOP CHORD 2x4 HF-N No.1/No.2
 BOT CHORD 2x4 HF-N No.1/No.2
 WEBS 2x4 HF-N No.1/No.2 *Except*
 12-8,16-2,17-1,11-9:2x4 DF Stud

BRACING

TOP CHORD Structural wood sheathing directly applied or
 3-3-12 oc purlins, except end verticals.
 BOT CHORD Rigid ceiling directly applied or 9-10-12 oc
 bracing.
 WEBS 1 Row at midpt 6-14, 4-14, 2-17, 8-11

REACTIONS

(size) 11=0-5-8, 17= Mechanical
 Max Horiz 17=95 (LC 17)
 Max Uplift 11=260 (LC 13), 17=238 (LC 12)
 Max Grav 11=1736 (LC 23), 17=1656 (LC 22)

FORCES

(lb) - Maximum Compression/Maximum
 Tension
 TOP CHORD 1-17=-302/103, 9-11=-444/169, 1-2=-356/92,
 2-4=-2534/429, 4-5=-1905/403,
 5-6=-1906/403, 6-8=-2524/424,
 8-9=-396/129, 9-10=0/46
 BOT CHORD 16-17=-371/2287, 14-16=-254/2095,
 12-14=-179/2068, 11-12=-280/2223
 WEBS 5-14=-175/1225, 6-14=-708/230,
 6-12=-35/382, 8-12=-107/154,
 4-14=-720/230, 4-16=-38/395,
 2-16=-127/158, 2-17=-2350/352,
 8-11=-2295/304

NOTES

- 1) Wind: ASCE 7-16; Vult=110mph (3-second gust)
 Vasd=87mph; TCDL=4.8psf; BCDL=4.2psf; h=25ft; Cat.
 II; Exp B; Partially Enclosed; MWFRS (envelope)
 exterior zone and C-C Exterior(2E) 0-1-12 to 3-11-15,
 Interior (1) 3-11-15 to 15-4-13, Exterior(2R) 15-4-13 to
 23-1-3, Interior (1) 23-1-3 to 36-1-13, Exterior(2E)
 36-1-13 to 40-0-0 zone; cantilever left and right
 exposed; end vertical left and right exposed; C-C for
 members and forces & MWFRS for reactions shown;
 Lumber DOL=1.60 plate grip DOL=1.60
- 2) TCLL: ASCE 7-16; Pf=25.0 psf (Lum DOL = 1.15 Plate
 DOL = 1.15); Is=1.0; Rough Cat B; Partially Exp.;
 Ce=1.0; Cs=1.00; Ct=1.10
- 3) Unbalanced snow loads have been considered for this
 design.
- 4) This truss has been designed for greater of min roof live
 load of 16.0 psf or 1.00 times flat roof load of 25.0 psf on
 overhangs non-concurrent with other live loads.
- 5) All plates are MT20 plates unless otherwise indicated.
- 6) This truss has been designed for a 10.0 psf bottom
 chord live load nonconcurrent with any other live loads.
- 7) * This truss has been designed for a live load of 20.0psf
 on the bottom chord in all areas where a rectangle
 3-06-00 tall by 2-00-00 wide will fit between the bottom
 chord and any other members, with BCDL = 7.0psf.
- 8) Refer to girder(s) for truss to truss connections.
- 9) Provide mechanical connection (by others) of truss to
 bearing plate capable of withstanding 238 lb uplift at joint
 17 and 260 lb uplift at joint 11.

LOAD CASE(S) Standard



October 3, 2025

WARNING - Verify design parameters and READ NOTES ON THIS AND INCLUDED MITEK REFERENCE PAGE MII-7473 rev. 1/2/2023 BEFORE USE.

Design valid for use only with MiTek® connectors. This design is based only upon parameters shown, and is for an individual building component, not a truss system. Before use, the building designer must verify the applicability of design parameters and properly incorporate this design into the overall building design. Bracing indicated is to prevent buckling of individual truss web and/or chord members only. Additional temporary and permanent bracing is always required for stability and to prevent collapse with possible personal injury and property damage. For general guidance regarding the fabrication, storage, delivery, erection and bracing of trusses and truss systems, see **ANSI/TPI1 Quality Criteria and DSB-22** available from Truss Plate Institute (www.tpin.org) and **BCSI Building Component Safety Information** available from the Structural Building Component Association (www.sbccomponents.com)

MiTek®

400 Sunrise Ave., Suite 270
 Roseville, CA 95661
 916.755.3571 / MiTek-US.com

Job J1183948	Truss B10	Truss Type Common Girder	Qty 1	Ply 2	NW Eastside Builders LLC Job Reference (optional)	R90572903
-----------------	--------------	-----------------------------	----------	----------	--	-----------

The Truss Company (Sumner, WA), Sumner, WA - 98390,

Run: 25.30 S Sep 17 2025 Print: 25.3.0 S Sep 17 2025 MiTek Industries, Inc. Thu Oct 02 17:24:50
ID:GyTCSQoRdhjJ5IDz3?M32fz98P9-RfC?PsB70Hq3NSgPqnL8w3uITXbGKWrCdoi7J4zJC7f

Page: 1

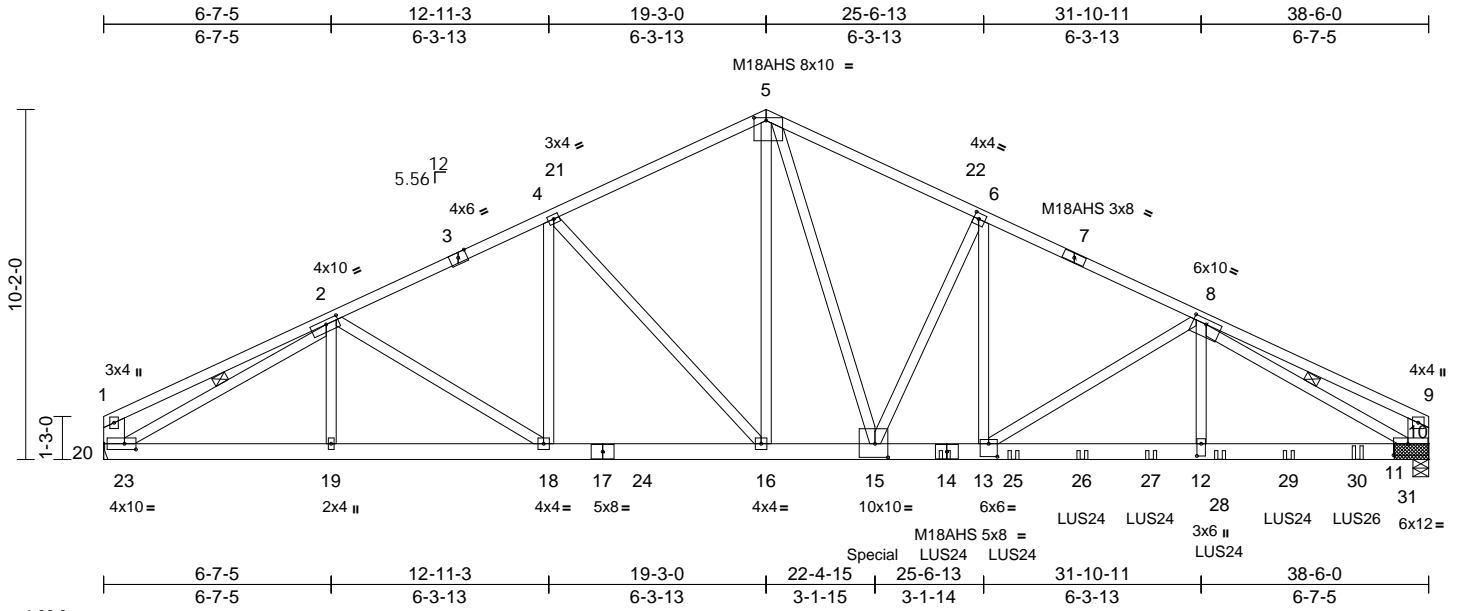

Scale = 1:66.9

Plate Offsets (X, Y): [2:0-4-7,0-1-8], [5:0-4-4,0-1-0], [6:0-1-12,0-2-0], [8:0-4-11,0-1-12], [10:0-5-0,0-4-0], [12:0-4-4,0-1-8], [13:0-3-0,0-4-8], [15:0-4-8,0-4-12], [20:0-4-0,0-2-0]

Loading	(psf)	Spacing	2-0-0	CSI	DEFL	in	(loc)	l/defl	L/d	PLATES	GRIP	
TCLL	25.0	Plate Grip DOL	1.15	TC	0.87	Vert(LL)	-0.30	12-13	>999	240	MT20	185/148
(Roof Snow = 25.0)		Lumber DOL	1.15	BC	0.87	Vert(CT)	-0.47	12-13	>961	180	M18AHS	145/140
TCDL	8.0	Rep Stress Incr	NO	WB	0.91	Horz(CT)	0.13	10	n/a	n/a		
BCLL	0.0*	Code	IRC2021/TPI2014	Matrix-MS								
BCDL	7.0											
											Weight: 510 lb	FT = 20%

LUMBER	
TOP CHORD	2x4 DF 2400F 2.0E *Except* 3-1:2x4 HF-N No.1/No.2, 7-9:2x4 DF 1800F 1.6E or 2x4 DF No.1&Btr or 2x4 DF-N 1800F 1.6E
BOT CHORD	2x6 DF SS
WEBS	2x4 HF-N No.1/No.2 *Except* 2-19,18-4,13-6,12-8:2x4 DF Stud, 20-1,10-9:2x8 DF SS, 20-2,10-8:2x4 DF 1800F 1.6E or 2x4 DF No.1&Btr or 2x4 DF-N 1800F 1.6E
BRACING	
TOP CHORD	Structural wood sheathing directly applied or 1-7-8 oc purlins, except end verticals.
BOT CHORD	Rigid ceiling directly applied or 10-0-0 oc bracing.
WEBS	1 Row at midpt 2-20, 8-10
REACTIONS	(size)
	10=(0-5-8 + bearing block), (req. 0-6-13), 20= Mechanical
Max Horiz	20=78 (LC 15)
Max Uplift	10=1370 (LC 11), 20=794 (LC 10)
Max Grav	10=8278 (LC 20), 20=4781 (LC 19)
FORCES	(lb) - Maximum Compression/Maximum Tension
TOP CHORD	1-2=-1018/228, 2-4=-8741/1501, 4-5=-8634/1539, 5-6=-11248/2009, 6-8=-12425/2134, 8-9=-2032/392, 1-20=-592/164, 9-10=-1055/236
BOT CHORD	19-20=-1242/7271, 18-19=-1243/7271, 16-18=-1280/7887, 15-16=-1197/7771, 13-15=-1778/11206, 12-13=-1933/11855, 10-12=-1934/11865
WEBS	2-19=-77/124, 2-20=-7528/1196, 4-18=-400/136, 2-18=-137/854, 5-16=-132/688, 4-16=-262/429, 6-13=-360/2599, 8-13=-977/183, 8-12=-234/2113, 8-10=-11923/1928, 5-15=-1430/7730, 6-15=-2875/520

NOTES

- 2-ply truss to be connected together with 10d (0.131"x3") nails as follows:
Top chords connected as follows: 2x4 - 1 row at 0-6-0 oc, 2x8 - 2 rows staggered at 0-9-0 oc.
Bottom chords connected as follows: 2x6 - 3 rows staggered at 0-2-0 oc.
Web connected as follows: 2x4 - 1 row at 0-9-0 oc.
- All loads are considered equally applied to all plies, except if noted as front (F) or back (B) face in the LOAD CASE(S) section. Ply to ply connections have been provided to distribute only loads noted as (F) or (B), unless otherwise indicated.
- 2x6 DF SS bearing block 12" long at jt. 10 attached to each face with 3 rows of 10d (0.131"x3") nails spaced 3" o.c. 12 Total fasteners per block. Bearing is assumed to be HF Stud.
- Wind: ASCE 7-16; Vult=110mph (3-second gust) Vasd=87mph; TCDL=4.8psf; BCDL=4.2psf; h=25ft; Cat. II; Exp B; Partially Enclosed; MWFRS (envelope) exterior zone; cantilever left and right exposed; end vertical left and right exposed; Lumber DOL=1.60 plate grip DOL=1.60
- TCLL: ASCE 7-16; Pf=25.0 psf (Lum DOL = 1.15 Plate DOL = 1.15); Is=1.0; Rough Cat B; Partially Exp.; Ce=1.0; Cs=1.00; Ct=1.10
- Unbalanced snow loads have been considered for this design.
- All plates are MT20 plates unless otherwise indicated.
- This truss has been designed for a 10.0 psf bottom chord live load nonconcurrent with any other live loads.
- * This truss has been designed for a live load of 20.0psf on the bottom chord in all areas where a rectangle 3-06-00 tall by 2-00-00 wide will fit between the bottom chord and any other members, with BCDL = 7.0psf.
- Refer to girder(s) for truss to truss connections.

- Provide mechanical connection (by others) of truss to bearing plate capable of withstanding 1370 lb uplift at joint 10 and 794 lb uplift at joint 20.
- Use Simpson Strong-Tie LUS24 (4-10d Girder, 2-10d Truss) or equivalent spaced at 2-0-0 oc max. starting at 24-5-4 from the left end to 34-5-4 to connect truss(es) to back face of bottom chord.
- Use Simpson Strong-Tie LUS26 (4-10d Girder, 3-10d Truss) or equivalent at 36-5-4 from the left end to connect truss(es) to back face of bottom chord, skewed 0.0 deg.to the left, sloping 0.0 deg. down.
- Fill all nail holes where hanger is in contact with lumber.
- Hanger(s) or other connection device(s) shall be provided sufficient to support concentrated load(s) 5465 lb down and 998 lb up at 22-4-8 on bottom chord. The design/selection of such connection device(s) is the responsibility of others.

LOAD CASE(S) Standard

- Dead + Snow (balanced): Lumber Increase=1.15, Plate Increase=1.15
Uniform Loads (lb/ft)
Vert: 1-5=-66, 5-9=-66, 10-20=-14



October 3, 2025

Continued on page 2

WARNING - Verify design parameters and READ NOTES ON THIS AND INCLUDED MITEK REFERENCE PAGE MII-7473 rev. 1/2023 BEFORE USE.

Design valid for use only with MiTek® connectors. This design is based only upon parameters shown, and is for an individual building component, not a truss system. Before use, the building designer must verify the applicability of design parameters and properly incorporate this design into the overall building design. Bracing indicated is to prevent buckling of individual truss web and/or chord members only. Additional temporary and permanent bracing is always required for stability and to prevent collapse with possible personal injury and property damage. For general guidance regarding the fabrication, storage, delivery, erection and bracing of trusses and truss systems, see **ANSI/TPI1 Quality Criteria and DSB-22** available from Truss Plate Institute (www.tpinst.org) and **BCSI Building Component Safety Information** available from the Structural Building Component Association (www.sbcsccomponents.com)

MiTek®

400 Sunrise Ave., Suite 270
Roseville, CA 95661
916.755.3571 / MiTek-US.com

Job J1183948	Truss B10	Truss Type Common Girder	Qty 1	Ply 2	NW Eastside Builders LLC Job Reference (optional)	R90572903
-----------------	--------------	-----------------------------	----------	-----------------	--	-----------

The Truss Company (Sumner, WA), Sumner, WA - 98390,

Run: 25.30 S Sep 17 2025 Print: 25.3.0 S Sep 17 2025 MiTek Industries, Inc. Thu Oct 02 17:24:50
ID:GyTCSQoRdhjJ5lDz3?M32fz98P9-RfC?PsB70Hq3NSgPqnL8w3ulTXbGKWrCDoi7J4zJC?f

Page: 2

Concentrated Loads (lb)

Vert: 14=-676 (B), 15=-4953 (B), 25=-676 (B),
26=-676 (B), 27=-676 (B), 28=-676 (B), 29=-676 (B),
30=-676 (B)

WARNING - Verify design parameters and READ NOTES ON THIS AND INCLUDED MITEK REFERENCE PAGE MII-7473 rev. 1/2/2023 BEFORE USE.

Design valid for use only with MiTek® connectors. This design is based only upon parameters shown, and is for an individual building component, not a truss system. Before use, the building designer must verify the applicability of design parameters and properly incorporate this design into the overall building design. Bracing indicated is to prevent buckling of individual truss web and/or chord members only. Additional temporary and permanent bracing is always required for stability and to prevent collapse with possible personal injury and property damage. For general guidance regarding the fabrication, storage, delivery, erection and bracing of trusses and truss systems, see **ANSI/TPI1 Quality Criteria and DSB-22** available from Truss Plate Institute (www.tpinst.org) and **BCSI Building Component Safety Information** available from the Structural Building Component Association (www.sbcsccomponents.com)

MiTek®

400 Sunrise Ave., Suite 270
Roseville, CA 95661
916.755.3571 / MiTek-US.com

Job J1183948	Truss B11	Truss Type Common	Qty 1	Ply 1	NW Eastside Builders LLC Job Reference (optional)	R90572904
-----------------	--------------	----------------------	----------	----------	--	-----------

The Truss Company (Sumner, WA), Sumner, WA - 98390,

Run: 25.30 S Sep 17 2025 Print: 25.3.0 S Sep 17 2025 MiTek Industries, Inc. Thu Oct 02 17:24:50
ID:BgEC6SWoXQrtk6WVOVR62sPz8DP1-RFC?PsB70Hq3NSgPqnL8w3uITXbGKWRcDoi7J4zJC?fi

Page: 1

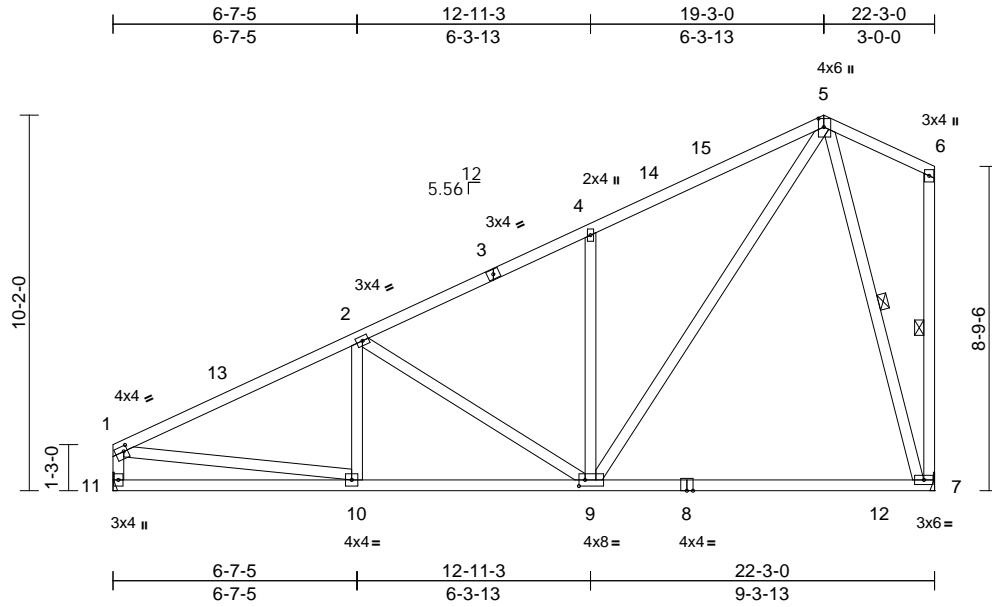

Scale = 1:62.4

Plate Offsets (X, Y): [1:0-1-4,0-1-12], [5:0-2-12,0-1-12], [9:0-2-0,0-2-0]

Loading	(psf)	Spacing	2-0-0	CSI	DEFL	in	(loc)	l/defl	L/d	PLATES	GRIP	
TCLL	25.0	Plate Grip DOL	1.15	TC	0.51	Vert(LL)	-0.37	7-9	>714	240	MT20	185/148
(Roof Snow = 25.0)		Lumber DOL	1.15	BC	0.66	Vert(CT)	-0.51	7-9	>513	180		
TCDL	8.0	Rep Stress Incr	YES	WB	0.61	Horz(CT)	0.02	7	n/a	n/a		
BCLL	0.0*	Code	IRC2021/TPI2014	Matrix-MS								
BCDL	7.0											
											Weight: 128 lb	FT = 20%

LUMBER

TOP CHORD 2x4 HF-N No.1/No.2
BOT CHORD 2x4 HF-N No.1/No.2
WEBS 2x4 DF Stud *Except* 7-6,9-5,9-2,7-5:2x4 HF-N No.1/No.2

BRACING

TOP CHORD Structural wood sheathing directly applied or 4-8-13 oc purlins, except end verticals.
BOT CHORD Rigid ceiling directly applied or 10-0-0 oc bracing.
WEBS 1 Row at midpt 6-7, 5-7

REACTIONS (size) 7= Mechanical, 11= Mechanical
Max Horiz 11=236 (LC 11)
Max Uplift 7=-174 (LC 12), 11=-146 (LC 12)
Max Grav 7=988 (LC 21), 11=947 (LC 24)

FORCES (lb) - Maximum Compression/Maximum Tension

TOP CHORD 5-6=-155/200, 1-11=-852/185, 6-7=-137/137, 1-2=-1344/241, 2-4=-1005/229, 4-5=-1010/338

BOT CHORD 10-11=-238/337, 9-10=-231/1146, 7-9=-69/243

WEBS 2-10=-70/110, 4-9=-495/213, 5-9=-273/1078, 1-10=-125/994, 2-9=-405/156, 5-7=-851/146

NOTES

- 1) Wind: ASCE 7-16; Vult=110mph (3-second gust) Vasd=87mph; TCDL=4.8psf; BCDL=4.2psf; h=25ft; Cat. II; Exp B; Partially Enclosed; MWFRS (envelope) exterior zone and C-C Exterior(2E) 0-1-12 to 3-1-12, Interior (1) 3-1-12 to 16-3-0, Exterior(2R) 16-3-0 to 19-3-0, Exterior(2E) 19-3-0 to 22-1-4 zone; cantilever left and right exposed; end vertical left and right exposed; C-C for members and forces & MWFRS for reactions shown; Lumber DOL=1.60 plate grip DOL=1.60

- 2) TCLL: ASCE 7-16; Pf=25.0 psf (Lum DOL = 1.15 Plate DOL = 1.15); Is=1.0; Rough Cat B; Partially Exp.; Ce=1.0; Cs=1.00; Ct=1.10
- 3) Unbalanced snow loads have been considered for this design.
- 4) This truss has been designed for a 10.0 psf bottom chord live load nonconcurrent with any other live loads.
- 5) * This truss has been designed for a live load of 20.0psf on the bottom chord in all areas where a rectangle 3-06-00 tall by 2-00-00 wide will fit between the bottom chord and any other members, with BCDL = 7.0psf.
- 6) Refer to girder(s) for truss to truss connections.
- 7) Provide mechanical connection (by others) of truss to bearing plate capable of withstanding 174 lb uplift at joint 7 and 146 lb uplift at joint 11.

LOAD CASE(S) Standard



October 3, 2025

WARNING - Verify design parameters and READ NOTES ON THIS AND INCLUDED MITEK REFERENCE PAGE MII-7473 rev. 1/2/2023 BEFORE USE.

Design valid for use only with MiTek® connectors. This design is based only upon parameters shown, and is for an individual building component, not a truss system. Before use, the building designer must verify the applicability of design parameters and properly incorporate this design into the overall building design. Bracing indicated is to prevent buckling of individual truss web and/or chord members only. Additional temporary and permanent bracing is always required for stability and to prevent collapse with possible personal injury and property damage. For general guidance regarding the fabrication, storage, delivery, erection and bracing of trusses and truss systems, see **ANSI/TPI1 Quality Criteria and DSB-22** available from Truss Plate Institute (www.tpinst.org) and **BCSI Building Component Safety Information** available from the Structural Building Component Association (www.sbcsccomponents.com)

MiTek®

400 Sunrise Ave., Suite 270
Roseville, CA 95661
916.755.3571 / MiTek-US.com

Job J1183948	Truss B12	Truss Type Common	Qty 1	Ply 1	NW Eastside Builders LLC Job Reference (optional)	R90572905
-----------------	--------------	----------------------	----------	----------	--	-----------

The Truss Company (Sumner, WA), Sumner, WA - 98390,

Run: 25.30 S Sep 17 2025 Print: 25.3.0 S Sep 17 2025 MiTek Industries, Inc. Thu Oct 02 17:24:50
ID: Ei85efKTg?0Gdydm69IEnez98SL-RfC?PsB70Hq3NSgPqnL8w3ulTXbGKWrCDoi7J4zJC?f

Page: 1

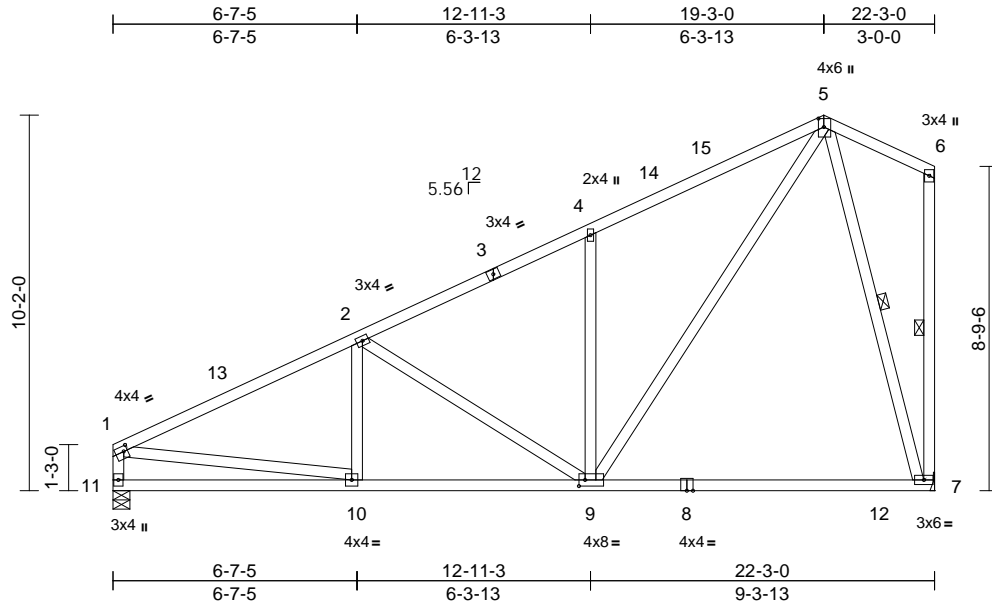

Scale = 1:62.4

Plate Offsets (X, Y): [1:0-1-4,0-1-12], [5:0-2-12,0-1-12], [9:0-2-0,0-2-0]

Loading	(psf)	Spacing	2-0-0	CSI	DEFL	in	(loc)	l/defl	L/d	PLATES	GRIP	
TCLL (Roof Snow = 25.0)	25.0	Plate Grip DOL	1.15	TC	0.51	Vert(LL)	-0.37	7-9	>714	240	MT20	185/148
TCDL	8.0	Lumber DOL	1.15	BC	0.66	Vert(CT)	-0.51	7-9	>513	180		
BCLL	0.0*	Rep Stress Incr	YES	WB	0.61	Horz(CT)	0.02	7	n/a	n/a		
BCDL	7.0	Code	IRC2021/TPI2014	Matrix-MS								
											Weight: 128 lb	FT = 20%

LUMBER

TOP CHORD 2x4 HF-N No.1/No.2
 BOT CHORD 2x4 HF-N No.1/No.2
 WEBS 2x4 DF Stud *Except* 7-6,9-5,9-2,7-5:2x4 HF-N No.1/No.2

BRACING

TOP CHORD Structural wood sheathing directly applied or 4-8-13 oc purlins, except end verticals.
 BOT CHORD Rigid ceiling directly applied or 10-0-0 oc bracing.
 WEBS 1 Row at midpt 6-7, 5-7

REACTIONS

(size) 7= Mechanical, 11=0-5-8
 Max Horiz 11=236 (LC 9)
 Max Uplift 7=-174 (LC 12), 11=-146 (LC 12)
 Max Grav 7=988 (LC 21), 11=947 (LC 24)

FORCES

(lb) - Maximum Compression/Maximum Tension
 TOP CHORD 5-6=-155/200, 1-11=-852/185, 6-7=-137/137, 1-2=-1344/241, 2-4=-1005/229, 4-5=-1010/338
 BOT CHORD 10-11=-238/337, 9-10=-231/1146, 7-9=-69/243
 WEBS 2-10=-70/110, 4-9=-495/213, 5-9=-273/1078, 1-10=-125/994, 2-9=-405/156, 5-7=-851/146

NOTES

- 1) Wind: ASCE 7-16; Vult=110mph (3-second gust) Vasd=87mph; TCDL=4.8psf; BCDL=4.2psf; h=25ft; Cat. II; Exp B; Partially Enclosed; MWFRS (envelope) exterior zone and C-C Exterior(2E) 0-1-12 to 3-1-12, Interior (1) 3-1-12 to 16-3-0, Exterior(2R) 16-3-0 to 19-3-0, Exterior(2E) 19-3-0 to 22-1-4 zone; cantilever left and right exposed; end vertical left and right exposed; C-C for members and forces & MWFRS for reactions shown; Lumber DOL=1.60 plate grip DOL=1.60

- 2) TCLL: ASCE 7-16; Pf=25.0 psf (Lum DOL = 1.15 Plate DOL = 1.15); Is=1.0; Rough Cat B; Partially Exp.; Ce=1.0; Cs=1.00; Ct=1.10
- 3) Unbalanced snow loads have been considered for this design.
- 4) This truss has been designed for a 10.0 psf bottom chord live load nonconcurrent with any other live loads.
- 5) * This truss has been designed for a live load of 20.0psf on the bottom chord in all areas where a rectangle 3-06-00 tall by 2-00-00 wide will fit between the bottom chord and any other members, with BCDL = 7.0psf.
- 6) Refer to girder(s) for truss to truss connections.
- 7) Provide mechanical connection (by others) of truss to bearing plate capable of withstanding 146 lb uplift at joint 11 and 174 lb uplift at joint 7.

LOAD CASE(S) Standard



October 3, 2025

WARNING - Verify design parameters and READ NOTES ON THIS AND INCLUDED MITEK REFERENCE PAGE MII-7473 rev. 1/2/2023 BEFORE USE.

Design valid for use only with MiTek® connectors. This design is based only upon parameters shown, and is for an individual building component, not a truss system. Before use, the building designer must verify the applicability of design parameters and properly incorporate this design into the overall building design. Bracing indicated is to prevent buckling of individual truss web and/or chord members only. Additional temporary and permanent bracing is always required for stability and to prevent collapse with possible personal injury and property damage. For general guidance regarding the fabrication, storage, delivery, erection and bracing of trusses and truss systems, see **ANSI/TPI1 Quality Criteria and DSB-22** available from Truss Plate Institute (www.tpinst.org) and **BCSI Building Component Safety Information** available from the Structural Building Component Association (www.sbcsccomponents.com)

MiTek®

400 Sunrise Ave., Suite 270
 Roseville, CA 95661
 916.755.3571 / MiTek-US.com

Job J1183948	Truss B13	Truss Type Common	Qty 7	Ply 1	NW Eastside Builders LLC Job Reference (optional)	R90572906
-----------------	--------------	----------------------	----------	----------	--	-----------

The Truss Company (Sumner, WA), Sumner, WA - 98390,

Run: 25.30 S Sep 17 2025 Print: 25.3.0 S Sep 17 2025 MiTek Industries, Inc. Thu Oct 02 17:24:50
ID: Ei85efKtg?0Gdydm69iEnez98SL-RfC?PsB70Hq3NSgPqnL8w3ulTXbGKWRcDoi7J4zJC?f

Page: 1

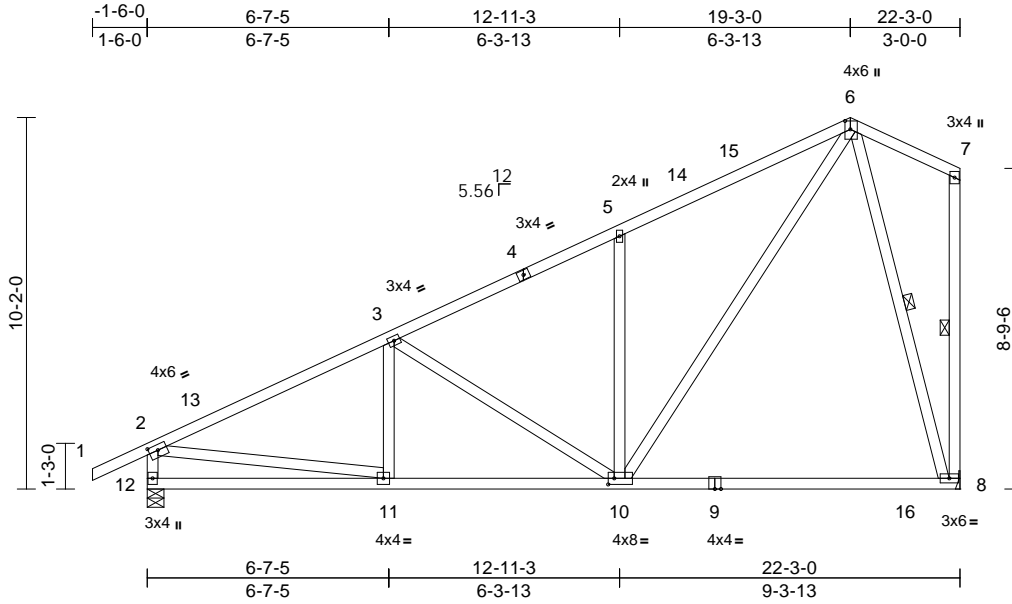

Scale = 1:63.1

Plate Offsets (X, Y): [2:0-3-0,0-1-12], [6:0-2-12,0-1-12], [10:0-2-0,0-2-0]

Loading	(psf)	Spacing	2-0-0	CSI	DEFL	in	(loc)	l/defl	L/d	PLATES	GRIP	
TCLL (Roof Snow = 25.0)	25.0	Plate Grip DOL	1.15	TC	0.51	Vert(LL)	-0.37	8-10	>714	240	MT20	185/148
TCDL	8.0	Lumber DOL	1.15	BC	0.66	Vert(CT)	-0.51	8-10	>513	180		
BCLL	0.0*	Rep Stress Incr	YES	WB	0.62	Horz(CT)	0.02	8	n/a	n/a		
BCDL	7.0	Code	IRC2021/TPI2014	Matrix-MS								
											Weight: 130 lb	FT = 20%

LUMBER

TOP CHORD 2x4 HF-N No.1/No.2
 BOT CHORD 2x4 HF-N No.1/No.2
 WEBS 2x4 DF Stud *Except* 8-7,10-6,10-3,8-6:2x4 HF-N No.1/No.2

BRACING

TOP CHORD Structural wood sheathing directly applied or 5-1-12 oc purlins, except end verticals.
 BOT CHORD Rigid ceiling directly applied or 10-0-0 oc bracing.
 WEBS 1 Row at midpt 7-8, 6-8

REACTIONS

(size) 8= Mechanical, 12=0-5-8
 Max Horiz 12=246 (LC 9)
 Max Uplift 8=-173 (LC 12), 12=-168 (LC 12)
 Max Grav 8=985 (LC 22), 12=1028 (LC 3)

FORCES

(lb) - Maximum Compression/Maximum Tension
 TOP CHORD 6-7=-155/200, 2-12=-965/237, 7-8=-138/137, 1-2=0/46, 2-3=-1333/235, 3-5=-1000/226, 5-6=-1007/337
 BOT CHORD 11-12=-260/368, 10-11=-228/1129, 8-10=-69/242
 WEBS 3-11=-64/112, 5-10=-502/215, 6-10=-274/1073, 2-11=-99/961, 3-10=-386/151, 6-8=-846/146

NOTES

1) Wind: ASCE 7-16; Vult=110mph (3-second gust)
 Vasd=87mph; TCDL=4.8psf; BCDL=4.2psf; h=25ft; Cat. II; Exp B; Partially Enclosed; MWFRS (envelope) exterior zone and C-C Exterior(2E) -1-6-0 to 1-6-0, Interior (1) 1-6-0 to 16-3-0, Exterior(2R) 16-3-0 to 19-3-0, Exterior(2E) 19-3-0 to 22-1-4 zone; cantilever left and right exposed; end vertical left and right exposed; C-C for members and forces & MWFRS for reactions shown; Lumber DOL=1.60 plate grip DOL=1.60

- TCLL: ASCE 7-16; Pf=25.0 psf (Lum DOL = 1.15 Plate DOL = 1.15); Is=1.0; Rough Cat B; Partially Exp.; Ce=1.0; Cs=1.00; Ct=1.10
- Unbalanced snow loads have been considered for this design.
- This truss has been designed for greater of min roof live load of 16.0 psf or 1.00 times flat roof load of 25.0 psf on overhangs non-concurrent with other live loads.
- This truss has been designed for a 10.0 psf bottom chord live load nonconcurrent with any other live loads.
- * This truss has been designed for a live load of 20.0psf on the bottom chord in all areas where a rectangle 3-06-00 tall by 2-00-00 wide will fit between the bottom chord and any other members, with BCDL = 7.0psf.
- Refer to girder(s) for truss to truss connections.
- Provide mechanical connection (by others) of truss to bearing plate capable of withstanding 168 lb uplift at joint 12 and 173 lb uplift at joint 8.

LOAD CASE(S) Standard



October 3, 2025

WARNING - Verify design parameters and READ NOTES ON THIS AND INCLUDED MITEK REFERENCE PAGE MII-7473 rev. 1/2/2023 BEFORE USE.

Design valid for use only with MiTek® connectors. This design is based only upon parameters shown, and is for an individual building component, not a truss system. Before use, the building designer must verify the applicability of design parameters and properly incorporate this design into the overall building design. Bracing indicated is to prevent buckling of individual truss web and/or chord members only. Additional temporary and permanent bracing is always required for stability and to prevent collapse with possible personal injury and property damage. For general guidance regarding the fabrication, storage, delivery, erection and bracing of trusses and truss systems, see **ANSI/TPI1 Quality Criteria and DSB-22** available from Truss Plate Institute (www.tpinst.org) and **BCSI Building Component Safety Information** available from the Structural Building Component Association (www.sbcsccomponents.com)

MiTek®

400 Sunrise Ave., Suite 270
 Roseville, CA 95661
 916.755.3571 / MiTek-US.com

Job J1183948	Truss M01	Truss Type Monopitch Supported Gable	Qty 2	Ply 1	NW Eastside Builders LLC Job Reference (optional)	R90572907
-----------------	--------------	---	----------	----------	--	-----------

The Truss Company (Sumner, WA), Sumner, WA - 98390,

Run: 25.30 S Sep 17 2025 Print: 25.3.0 S Sep 17 2025 MiTek Industries, Inc. Thu Oct 02 17:24:50
ID:mwMhbcnCf9VqX60e5MEU1Nz980t-RfC?PsB70Hq3NSgPqnL8w3uITXbGKWrCD0i7J4zJC?f

Page: 1

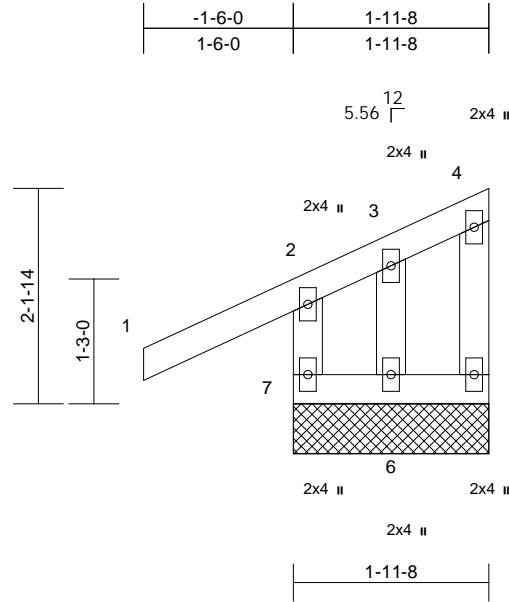

Loading	(psf)	Spacing	2-0-0	CSI		DEFL	in	(loc)	l/defl	L/d	PLATES	GRIP
TCLL	25.0	Plate Grip DOL	1.15	TC	0.22	Vert(LL)	n/a	-	n/a	999	MT20	185/148
(Roof Snow = 25.0)		Lumber DOL	1.15	BC	0.03	Vert(CT)	n/a	-	n/a	999		
TCDL	8.0	Rep Stress Incr	YES	WB	0.03	Horz(CT)	0.00	5	n/a	n/a		
BCLL	0.0*	Code	IRC2021/TPI2014	Matrix-MR								
BCDL	7.0										Weight: 12 lb	FT = 20%

LUMBER
TOP CHORD 2x4 HF-N No.1/No.2
BOT CHORD 2x4 HF-N No.1/No.2
WEBS 2x4 DF Stud
OTHERS 2x4 DF Stud

BRACING
TOP CHORD Structural wood sheathing directly applied or 1-11-8 oc purlins, except end verticals.
BOT CHORD Rigid ceiling directly applied or 6-0-0 oc bracing.

REACTIONS (size) 5=1-11-8, 6=1-11-8, 7=1-11-8
Max Horiz 7=56 (LC 9)
Max Uplift 5=-13 (LC 9), 6=-80 (LC 18), 7=-39 (LC 8)
Max Grav 5=42 (LC 19), 6=30 (LC 10), 7=356 (LC 19)

FORCES (lb) - Maximum Compression/Maximum Tension
TOP CHORD 2-7=-335/280, 1-2=0/67, 2-3=-67/40, 3-4=-22/23, 4-5=-46/44
BOT CHORD 6-7=-29/29, 5-6=-29/29
WEBS 3-6=-68/89

- NOTES**
- 1) Wind: ASCE 7-16; Vult=110mph (3-second gust) Vasd=87mph; TCCL=4.8psf; BCCL=4.2psf; h=25ft; Cat. II; Exp B; Partially Enclosed; MWFRS (envelope) exterior zone and C-C Corner(3E) zone; cantilever left and right exposed; end vertical left and right exposed; C-C for members and forces & MWFRS for reactions shown; Lumber DOL=1.60 plate grip DOL=1.60
 - 2) Truss designed for wind loads in the plane of the truss only. For studs exposed to wind (normal to the face), see Standard Industry Gable End Details as applicable, or consult qualified building designer as per ANSI/TPI 1.
 - 3) TCLL: ASCE 7-16; Pf=25.0 psf (Lum DOL = 1.15 Plate DOL = 1.15); Is=1.0; Rough Cat B; Partially Exp.; Ce=1.0; Cs=1.0; Ct=1.10

- 4) Unbalanced snow loads have been considered for this design.
- 5) This truss has been designed for greater of min roof live load of 16.0 psf or 1.00 times flat roof load of 25.0 psf on overhangs non-concurrent with other live loads.
- 6) Gable requires continuous bottom chord bearing.
- 7) Truss to be fully sheathed from one face or securely braced against lateral movement (i.e. diagonal web).
- 8) Gable studs spaced at 2-0-0 oc.
- 9) This truss has been designed for a 10.0 psf bottom chord live load nonconcurrent with any other live loads.
- 10) * This truss has been designed for a live load of 20.0psf on the bottom chord in all areas where a rectangle 3-06-00 tall by 2-00-00 wide will fit between the bottom chord and any other members.
- 11) Provide mechanical connection (by others) of truss to bearing plate capable of withstanding 39 lb uplift at joint 7, 13 lb uplift at joint 5 and 80 lb uplift at joint 6.

LOAD CASE(S) Standard



October 3, 2025

WARNING - Verify design parameters and READ NOTES ON THIS AND INCLUDED MITEK REFERENCE PAGE MII-7473 rev. 1/2/2023 BEFORE USE.

Design valid for use only with MiTek® connectors. This design is based only upon parameters shown, and is for an individual building component, not a truss system. Before use, the building designer must verify the applicability of design parameters and properly incorporate this design into the overall building design. Bracing indicated is to prevent buckling of individual truss web and/or chord members only. Additional temporary and permanent bracing is always required for stability and to prevent collapse with possible personal injury and property damage. For general guidance regarding the fabrication, storage, delivery, erection and bracing of trusses and truss systems, see **ANSI/TPI1 Quality Criteria and DSB-22** available from Truss Plate Institute (www.tpinst.org) and **BCSI Building Component Safety Information** available from the Structural Building Component Association (www.sbcsccomponents.com)

MiTek®

400 Sunrise Ave., Suite 270
Roseville, CA 95661
916.755.3571 / MiTek-US.com

Job J1183948	Truss M02	Truss Type Monopitch	Qty 9	Ply 1	NW Eastside Builders LLC Job Reference (optional)	R90572908
-----------------	--------------	-------------------------	----------	----------	--	-----------

The Truss Company (Sumner, WA), Sumner, WA - 98390,

Run: 25.30 S Sep 17 2025 Print: 25.30 S Sep 17 2025 MiTek Industries, Inc. Thu Oct 02 17:24:50
ID:mwMhbcnCf9VqX60e5MEU1Nz980t-RfC?PsB70Hq3NSgPqnL8w3uITXbGKWrCDoi7J4zJC?f

Page: 1

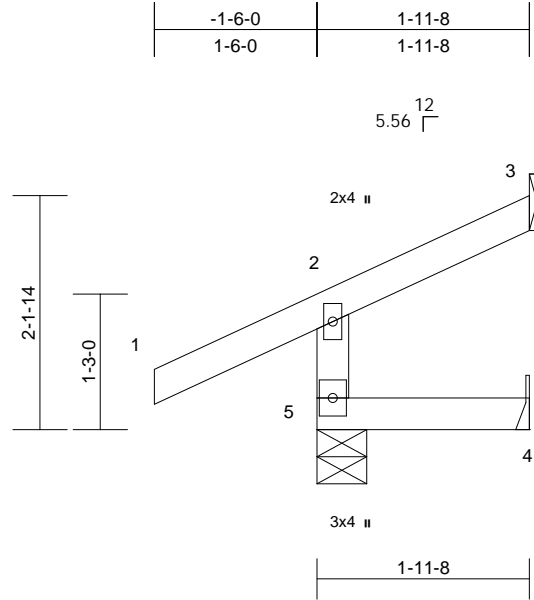

Scale = 1:21.2

Loading	(psf)	Spacing	2-0-0	CSI	DEFL	in	(loc)	l/defl	L/d	PLATES	GRIP	
TCLL	25.0	Plate Grip DOL	1.15	TC	0.26	Vert(LL)	0.00	4-5	>999	240	MT20	185/148
(Roof Snow = 25.0)		Lumber DOL	1.15	BC	0.12	Vert(CT)	0.00	4-5	>999	180		
TCDL	8.0	Rep Stress Incr	YES	WB	0.00	Horz(CT)	n/a	-	n/a	n/a		
BCLL	0.0*	Code	IRC2021/TPI2014	Matrix-MR								
BCDL	7.0											
										Weight: 8 lb	FT = 20%	

LUMBER

TOP CHORD 2x4 HF-N No.1/No.2
BOT CHORD 2x4 HF-N No.1/No.2
WEBS 2x4 DF Stud

BRACING

TOP CHORD Structural wood sheathing directly applied or 1-11-8 oc purlins, except end verticals.
BOT CHORD Rigid ceiling directly applied or 10-0-0 oc bracing.

REACTIONS

(size) 4= Mechanical, 5=0-5-8
Max Horiz 5=63 (LC 9)
Max Uplift 4=-25 (LC 9), 5=-15 (LC 9)
Max Grav 4=33 (LC 5), 5=332 (LC 19)

FORCES

(lb) - Maximum Compression/Maximum Tension

TOP CHORD 1-2=0/67, 2-3=-74/0, 2-5=-335/148
BOT CHORD 4-5=0/0

NOTES

- 1) Wind: ASCE 7-16; Vult=110mph (3-second gust)
Vasd=87mph; TCDL=4.8psf; BCDL=4.2psf; h=25ft; Cat. II; Exp B; Partially Enclosed; MWFRS (envelope) exterior zone and C-C Exterior(2E) zone; cantilever left and right exposed; end vertical left and right exposed; C-C for members and forces & MWFRS for reactions shown; Lumber DOL=1.60 plate grip DOL=1.60
- 2) TCLL: ASCE 7-16; Pf=25.0 psf (Lum DOL = 1.15 Plate DOL = 1.15); Is=1.0; Rough Cat B; Partially Exp.; Ce=1.0; Cs=1.00; Ct=1.10
- 3) Unbalanced snow loads have been considered for this design.
- 4) This truss has been designed for greater of min roof live load of 16.0 psf or 1.00 times flat roof load of 25.0 psf on overhangs non-concurrent with other live loads.
- 5) This truss has been designed for a 10.0 psf bottom chord live load nonconcurrent with any other live loads.

- 6) * This truss has been designed for a live load of 20.0psf on the bottom chord in all areas where a rectangle 3-06-00 tall by 2-00-00 wide will fit between the bottom chord and any other members.
 - 7) Refer to girder(s) for truss to truss connections.
 - 8) Provide mechanical connection (by others) of truss to bearing plate capable of withstanding 15 lb uplift at joint 5 and 25 lb uplift at joint 4.
- LOAD CASE(S)** Standard



October 3, 2025

WARNING - Verify design parameters and READ NOTES ON THIS AND INCLUDED MITEK REFERENCE PAGE MII-7473 rev. 1/2/2023 BEFORE USE.

Design valid for use only with MiTek® connectors. This design is based only upon parameters shown, and is for an individual building component, not a truss system. Before use, the building designer must verify the applicability of design parameters and properly incorporate this design into the overall building design. Bracing indicated is to prevent buckling of individual truss web and/or chord members only. Additional temporary and permanent bracing is always required for stability and to prevent collapse with possible personal injury and property damage. For general guidance regarding the fabrication, storage, delivery, erection and bracing of trusses and truss systems, see **ANSI/TPI1 Quality Criteria and DSB-22** available from Truss Plate Institute (www.tpinst.org) and **BCSI Building Component Safety Information** available from the Structural Building Component Association (www.sbcsccomponents.com)

MiTek®

400 Sunrise Ave., Suite 270
Roseville, CA 95661
916.755.3571 / MiTek-US.com

Job J1183948	Truss M03	Truss Type Monopitch	Qty 14	Ply 1	NW Eastside Builders LLC Job Reference (optional)	R90572909
-----------------	--------------	-------------------------	-----------	----------	--	-----------

The Truss Company (Sumner, WA), Sumner, WA - 98390,

Run: 25.30 S Sep 17 2025 Print: 25.30 S Sep 17 2025 MiTek Industries, Inc. Thu Oct 02 17:24:50
ID:E6w3p7dqQsdg9Gbf4mjaaaz980s-RfC?PsB70Hq3NSgPqnL8w3ulTXbGKWrcDoi7J4zJC?f

Page: 1

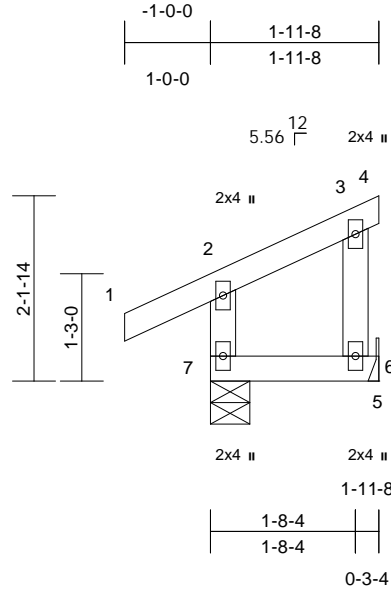

Loading (psf)		Spacing 2-0-0	CSI	DEFL in (loc) l/defl L/d	PLATES	GRIP
TCLL (Roof Snow = 25.0)	25.0	Plate Grip DOL 1.15	TC 0.10	Vert(LL) 0.00 6-7 >999 240	MT20	185/148
TCDL	8.0	Lumber DOL 1.15	BC 0.03	Vert(CT) 0.00 6-7 >999 180		
BCLL	0.0*	Rep Stress Incr YES	WB 0.00	Horz(CT) 0.00 5 n/a n/a		
BCDL	7.0	Code IRC2021/TPI2014	Matrix-MR		Weight: 10 lb	FT = 20%

LUMBER
TOP CHORD 2x4 HF-N No.1/No.2
BOT CHORD 2x4 HF-N No.1/No.2
WEBS 2x4 DF Stud

BRACING
TOP CHORD Structural wood sheathing directly applied or 1-11-8 oc purlins, except end verticals.
BOT CHORD Rigid ceiling directly applied or 6-0-0 oc bracing.

REACTIONS (size) 5= Mechanical, 7=0-5-8
Max Horiz 7=53 (LC 9)
Max Uplift 5=-28 (LC 9), 7=-25 (LC 12)
Max Grav 5=64 (LC 19), 7=240 (LC 19)

FORCES (lb) - Maximum Compression/Maximum Tension
TOP CHORD 1-2=0/46, 2-3=-44/24, 3-4=-11/0, 3-6=-65/26, 2-7=-215/96
BOT CHORD 6-7=-29/29, 5-6=0/0

- 6) * This truss has been designed for a live load of 20.0psf on the bottom chord in all areas where a rectangle 3-06-00 tall by 2-00-00 wide will fit between the bottom chord and any other members.
- 7) Refer to girder(s) for truss to truss connections.
- 8) Provide mechanical connection (by others) of truss to bearing plate capable of withstanding 25 lb uplift at joint 7 and 28 lb uplift at joint 5.
- LOAD CASE(S)** Standard

- NOTES**
- 1) Wind: ASCE 7-16; Vult=110mph (3-second gust) Vasd=87mph; TCDL=4.8psf; BCDL=4.2psf; h=25ft; Cat. II; Exp B; Partially Enclosed; MWFRS (envelope) exterior zone and C-C Exterior(2E) zone; cantilever left and right exposed; end vertical left and right exposed; C-C for members and forces & MWFRS for reactions shown; Lumber DOL=1.60 plate grip DOL=1.60
 - 2) TCLL: ASCE 7-16; Pf=25.0 psf (Lum DOL = 1.15 Plate DOL = 1.15); Is=1.0; Rough Cat B; Partially Exp.; Ce=1.0; Cs=1.00; Ct=1.10
 - 3) Unbalanced snow loads have been considered for this design.
 - 4) This truss has been designed for greater of min roof live load of 16.0 psf or 1.00 times flat roof load of 25.0 psf on overhangs non-concurrent with other live loads.
 - 5) This truss has been designed for a 10.0 psf bottom chord live load nonconcurrent with any other live loads.



October 3, 2025

WARNING - Verify design parameters and READ NOTES ON THIS AND INCLUDED MITEK REFERENCE PAGE MII-7473 rev. 1/2/2023 BEFORE USE.

Design valid for use only with MiTek® connectors. This design is based only upon parameters shown, and is for an individual building component, not a truss system. Before use, the building designer must verify the applicability of design parameters and properly incorporate this design into the overall building design. Bracing indicated is to prevent buckling of individual truss web and/or chord members only. Additional temporary and permanent bracing is always required for stability and to prevent collapse with possible personal injury and property damage. For general guidance regarding the fabrication, storage, delivery, erection and bracing of trusses and truss systems, see **ANSI/TPI1 Quality Criteria and DSB-22** available from Truss Plate Institute (www.tpinst.org) and **BCSI Building Component Safety Information** available from the Structural Building Component Association (www.sbcsccomponents.com)

MiTek®

400 Sunrise Ave., Suite 270
Roseville, CA 95661
916.755.3571 / MiTek-US.com

Job J1183948	Truss M04	Truss Type Monopitch Supported Gable	Qty 1	Ply 1	NW Eastside Builders LLC Job Reference (optional)	R90572910
-----------------	--------------	---	----------	----------	--	-----------

The Truss Company (Sumner, WA), Sumner, WA - 98390,

Run: 25.30 S Sep 17 2025 Print: 25.3.0 S Sep 17 2025 MiTek Industries, Inc. Thu Oct 02 17:24:50
ID:E6w3p7dqQsdg9Gbf4mjazz980s-RfC?PsB70Hq3NSgPqnL8w3uITXbGKWrCDoi7J4zJC?f

Page: 1

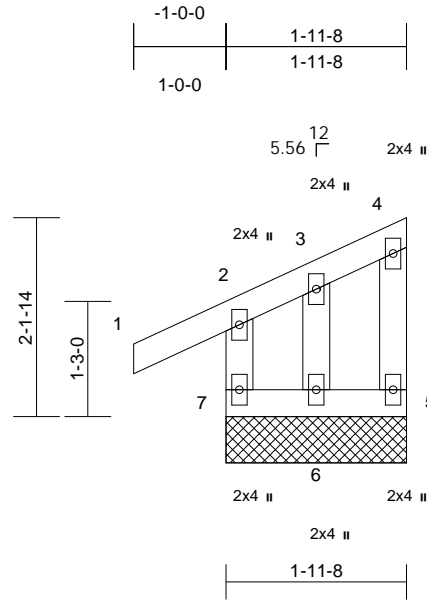

Scale = 1:25

Loading	(psf)	Spacing	2-0-0	CSI	DEFL	in	(loc)	l/defl	L/d	PLATES	GRIP	
TCLL	25.0	Plate Grip DOL	1.15	TC	0.14	Vert(LL)	n/a	-	n/a	999	MT20	185/148
(Roof Snow = 25.0)		Lumber DOL	1.15	BC	0.03	Vert(CT)	n/a	-	n/a	999		
TCDL	8.0	Rep Stress Incr	YES	WB	0.01	Horz(CT)	0.00	5	n/a	n/a		
BCLL	0.0*	Code	IRC2021/TPI2014	Matrix-MR								
BCDL	7.0											
										Weight: 11 lb	FT = 20%	

LUMBER

TOP CHORD	2x4 HF-N No.1/No.2
BOT CHORD	2x4 HF-N No.1/No.2
WEBS	2x4 DF Stud
OTHERS	2x4 DF Stud

BRACING

TOP CHORD	Structural wood sheathing directly applied or 1-11-8 oc purlins, except end verticals.
BOT CHORD	Rigid ceiling directly applied or 6-0-0 oc bracing.

REACTIONS

(size)	5=1-11-8, 6=1-11-8, 7=1-11-8
Max Horiz	7=53 (LC 9)
Max Uplift	5=-12 (LC 9), 6=-40 (LC 9), 7=-24 (LC 8)
Max Grav	5=40 (LC 19), 6=36 (LC 10), 7=221 (LC 19)

FORCES

(lb) - Maximum Compression/Maximum Tension	
TOP CHORD	2-7=-209/163, 1-2=0/45, 2-3=-41/40, 3-4=-23/26, 4-5=-39/36
BOT CHORD	6-7=-28/27, 5-6=-28/27
WEBS	3-6=-68/34

NOTES

- 1) Wind: ASCE 7-16; Vult=110mph (3-second gust) Vasd=87mph; TCDL=4.8psf; BCDL=4.2psf; h=25ft; Cat. II; Exp B; Partially Enclosed; MWFRS (envelope) exterior zone and C-C Corner(3E) zone; cantilever left and right exposed; end vertical left and right exposed; C-C for members and forces & MWFRS for reactions shown; Lumber DOL=1.60 plate grip DOL=1.60
- 2) Truss designed for wind loads in the plane of the truss only. For studs exposed to wind (normal to the face), see Standard Industry Gable End Details as applicable, or consult qualified building designer as per ANSI/TPI 1.
- 3) TCLL: ASCE 7-16; Pf=25.0 psf (Lum DOL = 1.15 Plate DOL = 1.15); Is=1.0; Rough Cat B; Partially Exp.; Ce=1.0; Cs=1.0; Ct=1.10

- 4) Unbalanced snow loads have been considered for this design.
- 5) This truss has been designed for greater of min roof live load of 16.0 psf or 1.00 times flat roof load of 25.0 psf on overhangs non-concurrent with other live loads.
- 6) Gable requires continuous bottom chord bearing.
- 7) Truss to be fully sheathed from one face or securely braced against lateral movement (i.e. diagonal web).
- 8) Gable studs spaced at 2-0-0 oc.
- 9) This truss has been designed for a 10.0 psf bottom chord live load nonconcurrent with any other live loads.
- 10) * This truss has been designed for a live load of 20.0psf on the bottom chord in all areas where a rectangle 3-06-00 tall by 2-00-00 wide will fit between the bottom chord and any other members.
- 11) Provide mechanical connection (by others) of truss to bearing plate capable of withstanding 24 lb uplift at joint 7, 12 lb uplift at joint 5 and 40 lb uplift at joint 6.

LOAD CASE(S) Standard



October 3, 2025

WARNING - Verify design parameters and READ NOTES ON THIS AND INCLUDED MITEK REFERENCE PAGE MII-7473 rev. 1/2/2023 BEFORE USE.

Design valid for use only with MiTek® connectors. This design is based only upon parameters shown, and is for an individual building component, not a truss system. Before use, the building designer must verify the applicability of design parameters and properly incorporate this design into the overall building design. Bracing indicated is to prevent buckling of individual truss web and/or chord members only. Additional temporary and permanent bracing is always required for stability and to prevent collapse with possible personal injury and property damage. For general guidance regarding the fabrication, storage, delivery, erection and bracing of trusses and truss systems, see **ANSI/TPI1 Quality Criteria and DSB-22** available from Truss Plate Institute (www.tpinst.org) and **BCSI Building Component Safety Information** available from the Structural Building Component Association (www.sbcsccomponents.com)

MiTek®

400 Sunrise Ave., Suite 270
Roseville, CA 95661
916.755.3571 / MiTek-US.com

Job J1183948	Truss M05	Truss Type Monopitch	Qty 4	Ply 1	NW Eastside Builders LLC Job Reference (optional)	R90572911
-----------------	--------------	-------------------------	----------	----------	--	-----------

The Truss Company (Sumner, WA), Sumner, WA - 98390,

Run: 25.30 S Sep 17 2025 Print: 25.3.0 S Sep 17 2025 MiTek Industries, Inc. Thu Oct 02 17:24:51
ID:E6w3p7dqQsdg9Gbfq4mjaaZ980s-RfC?PsB70Hq3NSgPqnL8w3ulTXbGKWrCDoi7J4zJC?f

Page: 1

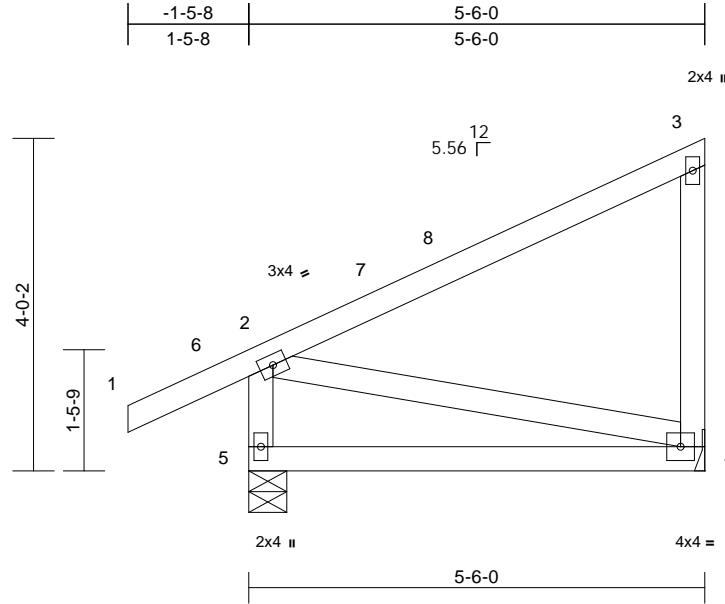

Scale = 1:27.8

Loading	(psf)	Spacing	2-0-0	CSI	DEFL	in	(loc)	l/defl	L/d	PLATES	GRIP	
TCLL	25.0	Plate Grip DOL	1.15	TC	0.59	Vert(LL)	-0.04	4-5	>999	240	MT20	185/148
(Roof Snow = 25.0)		Lumber DOL	1.15	BC	0.21	Vert(CT)	-0.07	4-5	>893	180		
TCDL	8.0	Rep Stress Incr	YES	WB	0.05	Horz(CT)	0.00	4	n/a	n/a		
BCLL	0.0*	Code	IRC2021/TPI2014	Matrix-MP								
BCDL	7.0											
												Weight: 29 lb FT = 20%

LUMBER

TOP CHORD 2x4 HF-N No.1/No.2
BOT CHORD 2x4 HF-N No.1/No.2
WEBS 2x4 DF Stud

BRACING

TOP CHORD Structural wood sheathing directly applied or 5-6-0 oc purlins, except end verticals.
BOT CHORD Rigid ceiling directly applied or 10-0-0 oc bracing.

REACTIONS

(size) 4= Mechanical, 5=0-5-8
Max Horiz 5=106 (LC 11)
Max Uplift 4=-84 (LC 9), 5=-63 (LC 8)
Max Grav 4=286 (LC 19), 5=449 (LC 19)

FORCES

(lb) - Maximum Compression/Maximum Tension
TOP CHORD 1-2=0/54, 2-3=-120/83, 3-4=-250/97,
2-5=-412/167
BOT CHORD 4-5=-107/114
WEBS 2-4=-95/97

NOTES

- 1) Wind: ASCE 7-16; Vult=110mph (3-second gust)
Vasd=87mph; TCDL=4.8psf; BCDL=4.2psf; h=25ft; Cat. II; Exp B; Partially Enclosed; MWFRS (envelope) exterior zone and C-C Exterior(2E) -1-5-8 to 1-6-8, Interior (1) 1-6-8 to 2-4-4, Exterior(2E) 2-4-4 to 5-4-4 zone; cantilever left and right exposed; end vertical left and right exposed; porch left and right exposed; C-C for members and forces & MWFRS for reactions shown; Lumber DOL=1.60 plate grip DOL=1.60
- 2) TCLL: ASCE 7-16; Pf=25.0 psf (Lum DOL = 1.15 Plate DOL = 1.15); Is=1.0; Rough Cat B; Partially Exp.; Ce=1.0; Cs=1.00; Ct=1.10
- 3) Unbalanced snow loads have been considered for this design.
- 4) This truss has been designed for greater of min roof live load of 16.0 psf or 1.00 times flat roof load of 25.0 psf on overhangs non-concurrent with other live loads.

- 5) This truss has been designed for a 10.0 psf bottom chord live load nonconcurrent with any other live loads.
- 6) * This truss has been designed for a live load of 20.0psf on the bottom chord in all areas where a rectangle 3-06-00 tall by 2-00-00 wide will fit between the bottom chord and any other members.
- 7) Refer to girder(s) for truss to truss connections.
- 8) Provide mechanical connection (by others) of truss to bearing plate capable of withstanding 84 lb uplift at joint 4 and 63 lb uplift at joint 5.

LOAD CASE(S) Standard



October 3, 2025

WARNING - Verify design parameters and READ NOTES ON THIS AND INCLUDED MITEK REFERENCE PAGE MII-7473 rev. 1/2/2023 BEFORE USE.

Design valid for use only with MiTek® connectors. This design is based only upon parameters shown, and is for an individual building component, not a truss system. Before use, the building designer must verify the applicability of design parameters and properly incorporate this design into the overall building design. Bracing indicated is to prevent buckling of individual truss web and/or chord members only. Additional temporary and permanent bracing is always required for stability and to prevent collapse with possible personal injury and property damage. For general guidance regarding the fabrication, storage, delivery, erection and bracing of trusses and truss systems, see **ANSI/TPI1 Quality Criteria and DSB-22** available from Truss Plate Institute (www.tpinst.org) and **BCSI Building Component Safety Information** available from the Structural Building Component Association (www.sbcsccomponents.com)

MiTek®

400 Sunrise Ave., Suite 270
Roseville, CA 95661
916.755.3571 / MiTek-US.com

Job J1183948	Truss M06	Truss Type Monopitch	Qty 6	Ply 1	NW Eastside Builders LLC Job Reference (optional)	R90572912
-----------------	--------------	-------------------------	----------	----------	--	-----------

The Truss Company (Sumner, WA), Sumner, WA - 98390,

Run: 25.30 S Sep 17 2025 Print: 25.3.0 S Sep 17 2025 MiTek Industries, Inc. Thu Oct 02 17:24:51
ID:E6w3p7dqQSdg9Gbqf4mjaaaz980s-RfC?PsB70Hq3NSgPqnL8w3ulTXbGKWrCDoi7J4zJC?f

Page: 1

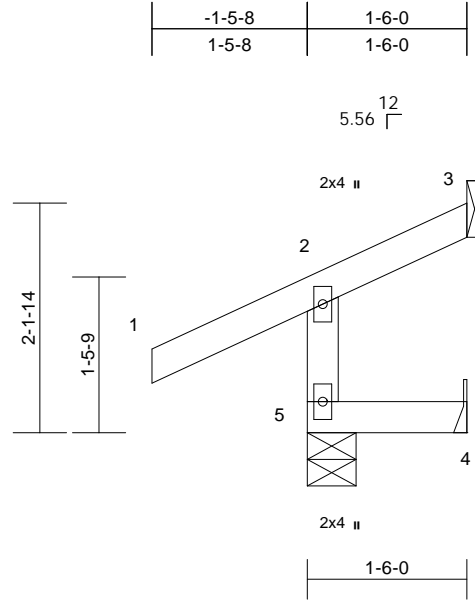

Scale = 1:21.6

Loading	(psf)	Spacing	2-0-0	CSI	DEFL	in	(loc)	l/defl	L/d	PLATES	GRIP	
TCLL	25.0	Plate Grip DOL	1.15	TC	0.21	Vert(LL)	0.00	4-5	>999	240	MT20	185/148
(Roof Snow = 25.0)		Lumber DOL	1.15	BC	0.07	Vert(CT)	0.00	4-5	>999	180		
TCDL	8.0	Rep Stress Incr	YES	WB	0.00	Horz(CT)	n/a	-	n/a	n/a		
BCLL	0.0*	Code	IRC2021/TPI2014	Matrix-MR								
BCDL	7.0										Weight: 7 lb	FT = 20%

LUMBER

TOP CHORD 2x4 HF-N No.1/No.2
BOT CHORD 2x4 HF-N No.1/No.2
WEBS 2x4 DF Stud

BRACING

TOP CHORD Structural wood sheathing directly applied or 1-6-0 oc purlins, except end verticals.
BOT CHORD Rigid ceiling directly applied or 10-0-0 oc bracing.

REACTIONS (size) 4= Mechanical, 5=0-5-8

Max Horiz 5=61 (LC 9)
Max Uplift 4=-41 (LC 9), 5=-17 (LC 8)
Max Grav 4=18 (LC 5), 5=315 (LC 19)

FORCES (lb) - Maximum Compression/Maximum Tension

TOP CHORD 1-2=0/64, 2-3=-54/0, 2-5=-279/127
BOT CHORD 4-5=0/0

NOTES

- 1) Wind: ASCE 7-16; Vult=110mph (3-second gust) Vasd=87mph; TCDL=4.8psf; BCDL=4.2psf; h=25ft; Cat. II; Exp B; Partially Enclosed; MWFRS (envelope) exterior zone and C-C Exterior(2E) zone; cantilever left and right exposed; end vertical left and right exposed; porch left and right exposed; C-C for members and forces & MWFRS for reactions shown; Lumber DOL=1.60 plate grip DOL=1.60
- 2) TCLL: ASCE 7-16; Pf=25.0 psf (Lum DOL = 1.15 Plate DOL = 1.15); Is=1.0; Rough Cat B; Partially Exp.; Ce=1.0; Cs=1.00; Ct=1.10
- 3) Unbalanced snow loads have been considered for this design.
- 4) This truss has been designed for greater of min roof live load of 16.0 psf or 1.00 times flat roof load of 25.0 psf on overhangs non-concurrent with other live loads.
- 5) This truss has been designed for a 10.0 psf bottom chord live load nonconcurrent with any other live loads.

- 6) * This truss has been designed for a live load of 20.0psf on the bottom chord in all areas where a rectangle 3-06-00 tall by 2-00-00 wide will fit between the bottom chord and any other members.
 - 7) Refer to girder(s) for truss to truss connections.
 - 8) Provide mechanical connection (by others) of truss to bearing plate capable of withstanding 17 lb uplift at joint 5 and 41 lb uplift at joint 4.
- LOAD CASE(S)** Standard



October 3, 2025

WARNING - Verify design parameters and READ NOTES ON THIS AND INCLUDED MITEK REFERENCE PAGE MII-7473 rev. 1/2/2023 BEFORE USE.

Design valid for use only with MiTek® connectors. This design is based only upon parameters shown, and is for an individual building component, not a truss system. Before use, the building designer must verify the applicability of design parameters and properly incorporate this design into the overall building design. Bracing indicated is to prevent buckling of individual truss web and/or chord members only. Additional temporary and permanent bracing is always required for stability and to prevent collapse with possible personal injury and property damage. For general guidance regarding the fabrication, storage, delivery, erection and bracing of trusses and truss systems, see **ANSI/TPI1 Quality Criteria and DSB-22** available from Truss Plate Institute (www.tpinst.org) and **BCSI Building Component Safety Information** available from the Structural Building Component Association (www.sbcsccomponents.com)

MiTek®

400 Sunrise Ave., Suite 270
Roseville, CA 95661
916.755.3571 / MiTek-US.com

Job J1183948	Truss M07	Truss Type Monopitch Supported Gable	Qty 1	Ply 1	NW Eastside Builders LLC Job Reference (optional)	R90572913
-----------------	--------------	---	----------	----------	--	-----------

The Truss Company (Sumner, WA), Sumner, WA - 98390,

Run: 25.30 S Sep 17 2025 Print: 25.3.0 S Sep 17 2025 MiTek Industries, Inc. Thu Oct 02 17:24:51
ID:E6w3p7dqQsdg9Gbfq4mjaaz980s-RfC?PsB70Hq3NSgPqnL8w3uITXbGKWrCDoi7J4zJC?F

Page: 1

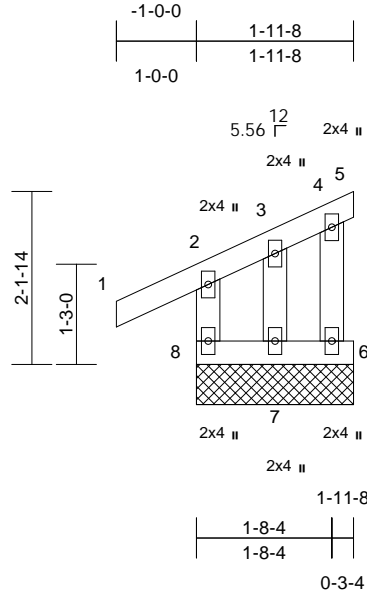

Scale = 1:28.7

Loading	(psf)	Spacing	2-0-0	CSI	DEFL	in	(loc)	l/defl	L/d	PLATES	GRIP	
TCLL	25.0	Plate Grip DOL	1.15	TC	0.14	Vert(LL)	n/a	-	n/a	999	MT20	185/148
(Roof Snow = 25.0)		Lumber DOL	1.15	BC	0.03	Vert(CT)	n/a	-	n/a	999		
TCDL	8.0	Rep Stress Incr	YES	WB	0.01	Horz(CT)	0.00	5	n/a	n/a		
BCLL	0.0*	Code	IRC2021/TPI2014	Matrix-MR								
BCDL	7.0											
											Weight: 11 lb	FT = 20%

LUMBER

TOP CHORD 2x4 HF-N No.1/No.2
BOT CHORD 2x4 HF-N No.1/No.2
WEBS 2x4 DF Stud
OTHERS 2x4 DF Stud

BRACING

TOP CHORD Structural wood sheathing directly applied or 1-11-8 oc purlins, except end verticals.
BOT CHORD Rigid ceiling directly applied or 6-0-0 oc bracing.

REACTIONS (size) 5=1-11-8, 6=1-11-8, 7=1-11-8, 8=1-11-8
Max Horiz 8=54 (LC 9)
Max Uplift 5=-18 (LC 12), 6=-7 (LC 11), 7=-34 (LC 9), 8=-21 (LC 8)
Max Grav 5=9 (LC 22), 6=42 (LC 19), 7=39 (LC 22), 8=214 (LC 19)

FORCES (lb) - Maximum Compression/Maximum Tension

TOP CHORD 2-8=-201/159, 1-2=0/46, 2-3=-35/33, 3-4=-19/19, 4-5=-21/9, 4-6=-48/6
BOT CHORD 7-8=-29/28, 6-7=-29/28
WEBS 3-7=-58/30

NOTES

- 1) Wind: ASCE 7-16; Vult=110mph (3-second gust) Vasd=87mph; TCDL=4.8psf; BCDL=4.2psf; h=25ft; Cat. II; Exp B; Partially Enclosed; MWFRS (envelope) exterior zone and C-C Corner(3E) zone; cantilever left and right exposed; end vertical left and right exposed; C-C for members and forces & MWFRS for reactions shown; Lumber DOL=1.60 plate grip DOL=1.60
- 2) Truss designed for wind loads in the plane of the truss only. For studs exposed to wind (normal to the face), see Standard Industry Gable End Details as applicable, or consult qualified building designer as per ANSI/TPI 1.

- 3) TCLL: ASCE 7-16; Pf=25.0 psf (Lum DOL = 1.15 Plate DOL = 1.15); Is=1.0; Rough Cat B; Partially Exp.; Ce=1.0; Cs=1.00; Ct=1.10
- 4) Unbalanced snow loads have been considered for this design.
- 5) This truss has been designed for greater of min roof live load of 16.0 psf or 1.00 times flat roof load of 25.0 psf on overhangs non-concurrent with other live loads.
- 6) Gable requires continuous bottom chord bearing.
- 7) Truss to be fully sheathed from one face or securely braced against lateral movement (i.e. diagonal web).
- 8) Gable studs spaced at 2-0-0 oc.
- 9) This truss has been designed for a 10.0 psf bottom chord live load nonconcurrent with any other live loads.
- 10) * This truss has been designed for a live load of 20.0psf on the bottom chord in all areas where a rectangle 3-06-00 tall by 2-00-00 wide will fit between the bottom chord and any other members.
- 11) Provide mechanical connection (by others) of truss to bearing plate capable of withstanding 21 lb uplift at joint 8, 18 lb uplift at joint 5, 7 lb uplift at joint 6 and 34 lb uplift at joint 7.

LOAD CASE(S) Standard



October 3, 2025

WARNING - Verify design parameters and READ NOTES ON THIS AND INCLUDED MITEK REFERENCE PAGE MII-7473 rev. 1/2/2023 BEFORE USE.

Design valid for use only with MiTek® connectors. This design is based only upon parameters shown, and is for an individual building component, not a truss system. Before use, the building designer must verify the applicability of design parameters and properly incorporate this design into the overall building design. Bracing indicated is to prevent buckling of individual truss web and/or chord members only. Additional temporary and permanent bracing is always required for stability and to prevent collapse with possible personal injury and property damage. For general guidance regarding the fabrication, storage, delivery, erection and bracing of trusses and truss systems, see **ANSI/TPI1 Quality Criteria and DSB-22** available from Truss Plate Institute (www.tpinst.org) and **BCSI Building Component Safety Information** available from the Structural Building Component Association (www.sbcsccomponents.com)

MiTek®

400 Sunrise Ave., Suite 270
Roseville, CA 95661
916.755.3571 / MiTek-US.com

Job J1183948	Truss M08	Truss Type Monopitch	Qty 1	Ply 1	NW Eastside Builders LLC Job Reference (optional)	R90572914
-----------------	--------------	-------------------------	----------	----------	--	-----------

The Truss Company (Sumner, WA), Sumner, WA - 98390,

Run: 25.30 S Sep 17 2025 Print: 25.3.0 S Sep 17 2025 MiTek Industries, Inc. Thu Oct 02 17:24:51
ID:E6w3p7dqQsdg9Gbfq4mjaaz980s-RfC?PsB70Hq3NSgPqnL8w3ulTXbGKWrCDoi7J4zJC?f

Page: 1

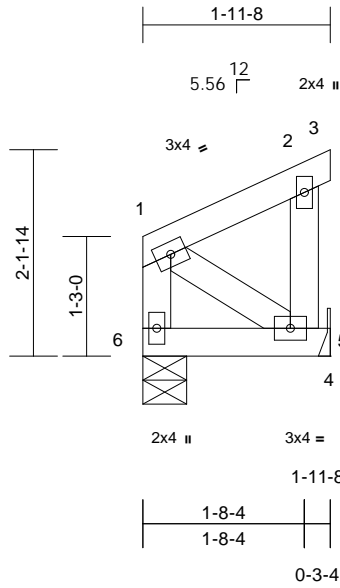

Scale = 1:24.1

Loading	(psf)	Spacing	2-0-0	CSI	DEFL	in	(loc)	l/defl	L/d	PLATES	GRIP
TCLL	25.0	Plate Grip DOL	1.15	TC	0.04	0.00	5-6	>999	240	MT20	185/148
(Roof Snow = 25.0)		Lumber DOL	1.15	BC	0.04	0.00	5-6	>999	180		
TCDL	8.0	Rep Stress Incr	YES	WB	0.01	0.00	4	n/a	n/a		
BCLL	0.0*	Code	IRC2021/TPI2014	Matrix-MP							
BCDL	7.0									Weight: 10 lb	FT = 20%

LUMBER

TOP CHORD 2x4 HF-N No.1/No.2
BOT CHORD 2x4 HF-N No.1/No.2
WEBS 2x4 DF Stud

BRACING

TOP CHORD Structural wood sheathing directly applied or 1-11-8 oc purlins, except end verticals.
BOT CHORD Rigid ceiling directly applied or 10-0-0 oc bracing.

REACTIONS (size)

4= Mechanical, 6=0-5-8
Max Horiz 6=46 (LC 11)
Max Uplift 4=-26 (LC 9), 6=-10 (LC 12)
Max Grav 4=93 (LC 18), 6=92 (LC 18)

FORCES (lb) - Maximum Compression/Maximum Tension

TOP CHORD 1-2=-34/26, 2-3=-10/0, 2-5=-94/26,
1-6=-66/37
BOT CHORD 5-6=-47/55, 4-5=0/0
WEBS 1-5=-54/39

NOTES

- 1) Wind: ASCE 7-16; Vult=110mph (3-second gust)
Vasd=87mph; TCDL=4.8psf; BCDL=4.2psf; h=25ft; Cat. II; Exp B; Partially Enclosed; MWFRS (envelope) exterior zone and C-C Exterior(2E) zone; cantilever left and right exposed; end vertical left and right exposed; C-C for members and forces & MWFRS for reactions shown; Lumber DOL=1.60 plate grip DOL=1.60
- 2) TCLL: ASCE 7-16; Pf=25.0 psf (Lum DOL = 1.15 Plate DOL = 1.15); Is=1.0; Rough Cat B; Partially Exp.; Ce=1.0; Cs=1.00; Ct=1.10
- 3) Unbalanced snow loads have been considered for this design.
- 4) This truss has been designed for a 10.0 psf bottom chord live load nonconcurrent with any other live loads.

- 5) * This truss has been designed for a live load of 20.0psf on the bottom chord in all areas where a rectangle 3-06-00 tall by 2-00-00 wide will fit between the bottom chord and any other members.
 - 6) Refer to girder(s) for truss to truss connections.
 - 7) Provide mechanical connection (by others) of truss to bearing plate capable of withstanding 10 lb uplift at joint 6 and 26 lb uplift at joint 4.
- LOAD CASE(S)** Standard



October 3, 2025

WARNING - Verify design parameters and READ NOTES ON THIS AND INCLUDED MITEK REFERENCE PAGE MII-7473 rev. 1/2/2023 BEFORE USE.

Design valid for use only with MiTek® connectors. This design is based only upon parameters shown, and is for an individual building component, not a truss system. Before use, the building designer must verify the applicability of design parameters and properly incorporate this design into the overall building design. Bracing indicated is to prevent buckling of individual truss web and/or chord members only. Additional temporary and permanent bracing is always required for stability and to prevent collapse with possible personal injury and property damage. For general guidance regarding the fabrication, storage, delivery, erection and bracing of trusses and truss systems, see **ANSI/TPI1 Quality Criteria and DSB-22** available from Truss Plate Institute (www.tpinst.org) and **BCSI Building Component Safety Information** available from the Structural Building Component Association (www.sbcsccomponents.com)

MiTek®

400 Sunrise Ave., Suite 270
Roseville, CA 95661
916.755.3571 / MiTek-US.com

Job J1183948	Truss M09	Truss Type Monopitch Supported Gable	Qty 2	Ply 1	NW Eastside Builders LLC Job Reference (optional)	R90572915
-----------------	--------------	---	----------	----------	--	-----------

The Truss Company (Sumner, WA), Sumner, WA - 98390,

Run: 25.30 S Sep 17 2025 Print: 25.30 S Sep 17 2025 MiTek Industries, Inc. Thu Oct 02 17:24:51
ID:E6w3p7dqQSDg9Gbfq4mjaaz980s-RfC?PsB70Hq3NSgPqnL8w3uITXbGKWrCdoi7J4zJC?f

Page: 1

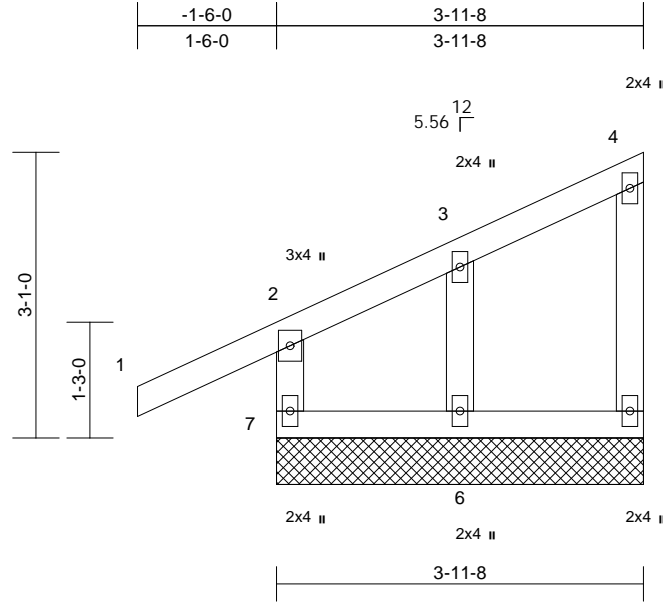

Scale = 1:24.9

Loading	(psf)	Spacing	2-0-0	CSI	DEFL	in	(loc)	l/defl	L/d	PLATES	GRIP	
TCLL	25.0	Plate Grip DOL	1.15	TC	0.24	Vert(LL)	n/a	-	n/a	999	MT20	185/148
(Roof Snow = 25.0)		Lumber DOL	1.15	BC	0.05	Vert(CT)	n/a	-	n/a	999		
TCDL	8.0	Rep Stress Incr	YES	WB	0.03	Horz(CT)	0.00	5	n/a	n/a		
BCLL	0.0*	Code	IRC2021/TPI2014	Matrix-MR								
BCDL	7.0											
											Weight: 19 lb	FT = 20%

LUMBER

TOP CHORD	2x4 HF-N No.1/No.2
BOT CHORD	2x4 HF-N No.1/No.2
WEBS	2x4 DF Stud
OTHERS	2x4 DF Stud

BRACING

TOP CHORD	Structural wood sheathing directly applied or 3-11-8 oc purlins, except end verticals.
BOT CHORD	Rigid ceiling directly applied or 6-0-0 oc bracing.

REACTIONS

(size)	5=3-11-8, 6=3-11-8, 7=3-11-8
Max Horiz	7=81 (LC 11)
Max Uplift	5=-9 (LC 9), 6=-62 (LC 12), 7=-24 (LC 8)
Max Grav	5=99 (LC 19), 6=154 (LC 19), 7=344 (LC 19)

FORCES

(lb) - Maximum Compression/Maximum Tension

TOP CHORD	2-7=-320/178, 1-2=0/71, 2-3=-64/77, 3-4=-48/36, 4-5=-89/50
BOT CHORD	6-7=-37/48, 5-6=-37/48
WEBS	3-6=-137/143

NOTES

- 1) Wind: ASCE 7-16; Vult=110mph (3-second gust) Vasd=87mph; TCDL=4.8psf; BCDL=4.2psf; h=25ft; Cat. II; Exp B; Partially Enclosed; MWFRS (envelope) exterior zone and C-C Corner(3E) zone; cantilever left and right exposed; end vertical left and right exposed; C-C for members and forces & MWFRS for reactions shown; Lumber DOL=1.60 plate grip DOL=1.60
- 2) Truss designed for wind loads in the plane of the truss only. For studs exposed to wind (normal to the face), see Standard Industry Gable End Details as applicable, or consult qualified building designer as per ANSI/TPI 1.
- 3) TCLL: ASCE 7-16; Pf=25.0 psf (Lum DOL = 1.15 Plate DOL = 1.15); Is=1.0; Rough Cat B; Partially Exp.; Ce=1.0; Cs=1.0; Ct=1.10

- 4) Unbalanced snow loads have been considered for this design.
- 5) This truss has been designed for greater of min roof live load of 16.0 psf or 1.00 times flat roof load of 25.0 psf on overhangs non-concurrent with other live loads.
- 6) Gable requires continuous bottom chord bearing.
- 7) Truss to be fully sheathed from one face or securely braced against lateral movement (i.e. diagonal web).
- 8) Gable studs spaced at 2-0-0 oc.
- 9) This truss has been designed for a 10.0 psf bottom chord live load nonconcurrent with any other live loads.
- 10) * This truss has been designed for a live load of 20.0psf on the bottom chord in all areas where a rectangle 3-06-00 tall by 2-00-00 wide will fit between the bottom chord and any other members.
- 11) Provide mechanical connection (by others) of truss to bearing plate capable of withstanding 24 lb uplift at joint 7, 9 lb uplift at joint 5 and 62 lb uplift at joint 6.

LOAD CASE(S) Standard



October 3, 2025

WARNING - Verify design parameters and READ NOTES ON THIS AND INCLUDED MITEK REFERENCE PAGE MII-7473 rev. 1/2/2023 BEFORE USE.

Design valid for use only with MiTek® connectors. This design is based only upon parameters shown, and is for an individual building component, not a truss system. Before use, the building designer must verify the applicability of design parameters and properly incorporate this design into the overall building design. Bracing indicated is to prevent buckling of individual truss web and/or chord members only. Additional temporary and permanent bracing is always required for stability and to prevent collapse with possible personal injury and property damage. For general guidance regarding the fabrication, storage, delivery, erection and bracing of trusses and truss systems, see **ANSI/TPI1 Quality Criteria and DSB-22** available from Truss Plate Institute (www.tpinst.org) and **BCSI Building Component Safety Information** available from the Structural Building Component Association (www.sbcsccomponents.com)

MiTek®

400 Sunrise Ave., Suite 270
Roseville, CA 95661
916.755.3571 / MiTek-US.com

Job J1183948	Truss Z01B	Truss Type Blocking Supported Gable	Qty 56	Ply 1	NW Eastside Builders LLC Job Reference (optional)	R90572916
-----------------	---------------	--	-----------	----------	--	-----------

The Truss Company (Sumner, WA), Sumner, WA - 98390,

Run: 25.30 S Sep 17 2025 Print: 25.3.0 S Sep 17 2025 MiTek Industries, Inc. Thu Oct 02 17:24:51
ID:xm?QLkXR3JlgpBZUI684o6z980z-RfC?PsB70Hq3NSgPqnL8w3uITXbGKWrCDoi7J4zJC?f

Page: 1

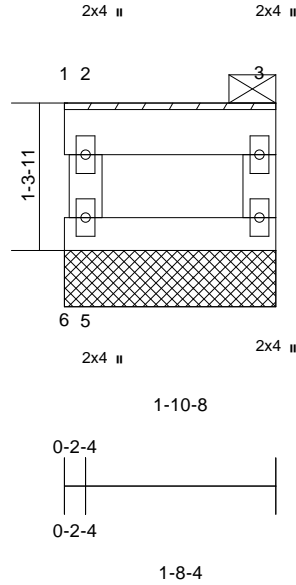

Scale = 1:20.4

Loading	(psf)	Spacing	2-0-0	CSI	DEFL	in	(loc)	l/defl	L/d	PLATES	GRIP	
TCLL (Roof Snow = 25.0)	25.0	Plate Grip DOL	1.15	TC	0.04	Vert(LL)	n/a	-	n/a	999	MT20	185/148
TCDL	8.0	Lumber DOL	1.15	BC	0.02	Vert(TL)	n/a	-	n/a	999		
BCLL	0.0*	Rep Stress Incr	YES	WB	0.02	Horiz(TL)	0.00	1	n/a	n/a		
BCDL	7.0	Code	IRC2021/TPI2014	Matrix-MP							Weight: 8 lb	FT = 20%

LUMBER

TOP CHORD 2x6 DF SS
BOT CHORD 2x4 HF-N No.1/No.2
WEBS 2x4 DF Stud

BRACING

TOP CHORD 2-0-0 oc purlins: 1-3, except end verticals.
BOT CHORD Rigid ceiling directly applied or 10-0-0 oc bracing.

REACTIONS

(size) 1=1-10-8, 4=1-10-8, 5=1-10-8, 6=1-10-8
Max Horiz 6=24 (LC 9)
Max Uplift 1=-3 (LC 7), 4=-15 (LC 7), 5=-23 (LC 6), 6=-41 (LC 3)
Max Grav 1=8 (LC 1), 4=59 (LC 1), 5=93 (LC 3), 6=3 (LC 6)

FORCES

(lb) - Maximum Compression/Maximum Tension

TOP CHORD 1-2=0/0, 2-3=0/0, 3-4=-52/49
BOT CHORD 5-6=-24/38, 4-5=-24/38
WEBS 2-5=-54/64

NOTES

- 1) Wind: ASCE 7-16; Vult=110mph (3-second gust) Vasd=87mph; TCDL=4.8psf; BCDL=4.2psf; h=25ft; Cat. II; Exp B; Partially Enclosed; MWFRS (envelope) exterior zone and C-C Corner (3) zone; cantilever left and right exposed; end vertical left and right exposed; C-C for members and forces & MWFRS for reactions shown; Lumber DOL=1.60 plate grip DOL=1.60
- 2) Truss designed for wind loads in the plane of the truss only. For studs exposed to wind (normal to the face), see Standard Industry Gable End Details as applicable, or consult qualified building designer as per ANSI/TPI 1.
- 3) TCLL: ASCE 7-16; Pf=25.0 psf (Lum DOL = 1.15 Plate DOL = 1.15); Is=1.0; Rough Cat B; Partially Exp.; Ce=1.0; Cs=1.00; Ct=1.10
- 4) Provide adequate drainage to prevent water ponding.
- 5) Gable requires continuous bottom chord bearing.

- 6) Truss to be fully sheathed from one face or securely braced against lateral movement (i.e. diagonal web).
- 7) Gable studs spaced at 2-0-0 oc.
- 8) This truss has been designed for a 10.0 psf bottom chord live load nonconcurrent with any other live loads.
- 9) * This truss has been designed for a live load of 20.0psf on the bottom chord in all areas where a rectangle 3-06-00 tall by 2-00-00 wide will fit between the bottom chord and any other members.
- 10) Provide mechanical connection (by others) of truss to bearing plate capable of withstanding 41 lb uplift at joint 6, 15 lb uplift at joint 4, 3 lb uplift at joint 1 and 23 lb uplift at joint 5.
- 11) Graphical purlin representation does not depict the size or the orientation of the purlin along the top and/or bottom chord.

LOAD CASE(S) Standard



October 3, 2025

WARNING - Verify design parameters and READ NOTES ON THIS AND INCLUDED MITEK REFERENCE PAGE MII-7473 rev. 1/2/2023 BEFORE USE.

Design valid for use only with MiTek® connectors. This design is based only upon parameters shown, and is for an individual building component, not a truss system. Before use, the building designer must verify the applicability of design parameters and properly incorporate this design into the overall building design. Bracing indicated is to prevent buckling of individual truss web and/or chord members only. Additional temporary and permanent bracing is always required for stability and to prevent collapse with possible personal injury and property damage. For general guidance regarding the fabrication, storage, delivery, erection and bracing of trusses and truss systems, see **ANSI/TPI1 Quality Criteria and DSB-22** available from Truss Plate Institute (www.tpinst.org) and **BCSI Building Component Safety Information** available from the Structural Building Component Association (www.sbcsccomponents.com)

MiTek®

400 Sunrise Ave., Suite 270
Roseville, CA 95661
916.755.3571 / MiTek-US.com

Job J1183948	Truss Z02B	Truss Type Blocking Supported Gable	Qty 10	Ply 1	NW Eastside Builders LLC Job Reference (optional)	R90572917
-----------------	---------------	--	-----------	----------	--	-----------

The Truss Company (Sumner, WA), Sumner, WA - 98390,

Run: 25.30 S Sep 17 2025 Print: 25.3.0 S Sep 17 2025 MiTek Industries, Inc. Thu Oct 02 17:24:51
ID:xm?QLkXR3JlgpBZUI684o6z980z-RfC?PsB70Hq3NSgPqnL8w3uITXbGKWrCDoi7J4zJC?f

Page: 1

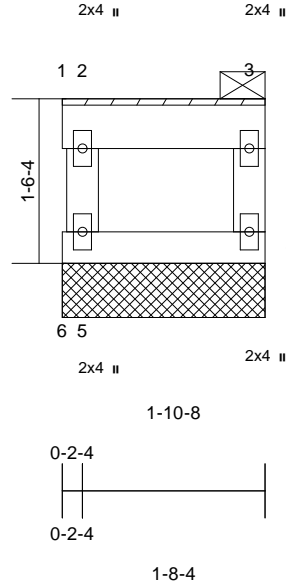

Scale = 1:21.3

Loading	(psf)	Spacing	2-0-0	CSI	DEFL	in	(loc)	l/defl	L/d	PLATES	GRIP	
TCLL	25.0	Plate Grip DOL	1.15	TC	0.04	Vert(LL)	n/a	-	n/a	999	MT20	185/148
(Roof Snow = 25.0)		Lumber DOL	1.15	BC	0.02	Vert(CT)	n/a	-	n/a	999		
TCDL	8.0	Rep Stress Incr	YES	WB	0.01	Horz(CT)	0.00	4	n/a	n/a		
BCLL	0.0*	Code	IRC2021/TPI2014	Matrix-MS								
BCDL	7.0										Weight: 8 lb	FT = 20%

LUMBER

TOP CHORD 2x6 DF SS
BOT CHORD 2x4 HF-N No.1/No.2
WEBS 2x4 DF Stud

BRACING

TOP CHORD 2-0-0 oc purlins: 1-3, except end verticals.
BOT CHORD Rigid ceiling directly applied or 10-0-0 oc bracing.

REACTIONS (size)

4=1-10-8, 5=1-10-8
Max Horiz 5=30 (LC 9)
Max Uplift 4=-14 (LC 7), 5=-22 (LC 6)
Max Grav 4=61 (LC 1), 5=78 (LC 1)

FORCES (lb) - Maximum Compression/Maximum Tension

TOP CHORD 1-2=0/0, 2-3=0/0, 3-4=-50/45
BOT CHORD 5-6=0/0, 4-5=-30/47
WEBS 2-5=-64/60

NOTES

- 1) Wind: ASCE 7-16; Vult=110mph (3-second gust)
Vasd=87mph; TCDL=4.8psf; BCDL=4.2psf; h=25ft; Cat. II; Exp B; Partially Enclosed; MWFRS (envelope) exterior zone and C-C Corner (3) zone; cantilever left and right exposed; end vertical left and right exposed; C-C for members and forces & MWFRS for reactions shown; Lumber DOL=1.60 plate grip DOL=1.60
- 2) Truss designed for wind loads in the plane of the truss only. For studs exposed to wind (normal to the face), see Standard Industry Gable End Details as applicable, or consult qualified building designer as per ANSI/TPI 1.
- 3) TCLL: ASCE 7-16; Pf=25.0 psf (Lum DOL = 1.15 Plate DOL = 1.15); Is=1.0; Rough Cat B; Partially Exp.; Ce=1.0; Cs=1.00; Ct=1.10
- 4) Provide adequate drainage to prevent water ponding.
- 5) Gable requires continuous bottom chord bearing.
- 6) Truss to be fully sheathed from one face or securely braced against lateral movement (i.e. diagonal web).
- 7) Gable studs spaced at 2-0-0 oc.

- 8) This truss has been designed for a 10.0 psf bottom chord live load nonconcurrent with any other live loads.
 - 9) * This truss has been designed for a live load of 20.0psf on the bottom chord in all areas where a rectangle 3-06-00 tall by 2-00-00 wide will fit between the bottom chord and any other members.
 - 10) Provide mechanical connection (by others) of truss to bearing plate capable of withstanding 14 lb uplift at joint 4 and 22 lb uplift at joint 5.
 - 11) Graphical purlin representation does not depict the size or the orientation of the purlin along the top and/or bottom chord.
- LOAD CASE(S)** Standard



October 3, 2025

WARNING - Verify design parameters and READ NOTES ON THIS AND INCLUDED MITEK REFERENCE PAGE MII-7473 rev. 1/2/2023 BEFORE USE.

Design valid for use only with MiTek® connectors. This design is based only upon parameters shown, and is for an individual building component, not a truss system. Before use, the building designer must verify the applicability of design parameters and properly incorporate this design into the overall building design. Bracing indicated is to prevent buckling of individual truss web and/or chord members only. Additional temporary and permanent bracing is always required for stability and to prevent collapse with possible personal injury and property damage. For general guidance regarding the fabrication, storage, delivery, erection and bracing of trusses and truss systems, see **ANSI/TPI1 Quality Criteria and DSB-22** available from Truss Plate Institute (www.tpinst.org) and **BCSI Building Component Safety Information** available from the Structural Building Component Association (www.sbcsccomponents.com)

MiTek®

400 Sunrise Ave., Suite 270
Roseville, CA 95661
916.755.3571 / MiTek-US.com

Job J1183948	Truss Z03B	Truss Type Blocking Supported Gable	Qty 2	Ply 1	NW Eastside Builders LLC Job Reference (optional)	R90572918
-----------------	---------------	--	----------	----------	--	-----------

The Truss Company (Sumner, WA), Sumner, WA - 98390,

Run: 25.30 S Sep 17 2025 Print: 25.3.0 S Sep 17 2025 MiTek Industries, Inc. Thu Oct 02 17:24:51
ID:xm?QLkXR3JlgpBZUI684o6z980z-RfC?PsB70Hq3NSgPqnL8w3uITXbGKWrCDoi7J4zJC?f

Page: 1

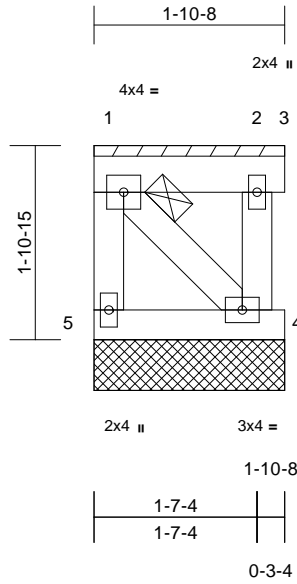

Scale = 1:22.7

Loading	(psf)	Spacing	2-0-0	CSI	DEFL	in	(loc)	l/defl	L/d	PLATES	GRIP	
TCLL	25.0	Plate Grip DOL	1.15	TC	0.04	Vert(LL)	n/a	-	n/a	999	MT20	185/148
(Roof Snow = 25.0)		Lumber DOL	1.15	BC	0.01	Vert(TL)	n/a	-	n/a	999		
TCDL	8.0	Rep Stress Incr	YES	WB	0.01	Horiz(TL)	0.00	3	n/a	n/a		
BCLL	0.0*	Code	IRC2021/TPI2014	Matrix-MP								
BCDL	7.0											
											Weight: 12 lb	FT = 20%

LUMBER

TOP CHORD 2x6 DF SS
BOT CHORD 2x4 HF-N No.1/No.2
WEBS 2x4 DF Stud

BRACING

TOP CHORD 2-0-0 oc purlins: 1-3, except end verticals.
BOT CHORD Rigid ceiling directly applied or 10-0-0 oc bracing.

REACTIONS

(size) 3=1-10-8, 4=1-10-8, 5=1-10-8
Max Horiz 5=-38 (LC 6)
Max Uplift 3=-8 (LC 7), 4=-29 (LC 7), 5=-32 (LC 6)
Max Grav 3=17 (LC 1), 4=57 (LC 1), 5=60 (LC 1)

FORCES

(lb) - Maximum Compression/Maximum Tension

TOP CHORD 1-5=-50/92, 1-2=-20/31, 2-3=0/0, 2-4=-47/54
BOT CHORD 4-5=-39/70
WEBS 1-4=-56/27

NOTES

- 1) Wind: ASCE 7-16; Vult=110mph (3-second gust)
Vasd=87mph; TCDL=4.8psf; BCDL=4.2psf; h=25ft; Cat. II; Exp B; Partially Enclosed; MWFRS (envelope) exterior zone and C-C Corner (3) zone; cantilever left and right exposed; end vertical left and right exposed; C-C for members and forces & MWFRS for reactions shown; Lumber DOL=1.60 plate grip DOL=1.60
- 2) Truss designed for wind loads in the plane of the truss only. For studs exposed to wind (normal to the face), see Standard Industry Gable End Details as applicable, or consult qualified building designer as per ANSI/TPI 1.
- 3) TCLL: ASCE 7-16; Pf=25.0 psf (Lum DOL = 1.15 Plate DOL = 1.15); Is=1.0; Rough Cat B; Partially Exp.; Ce=1.0; Cs=1.00; Ct=1.10
- 4) Provide adequate drainage to prevent water ponding.
- 5) Gable requires continuous bottom chord bearing.

- 6) Truss to be fully sheathed from one face or securely braced against lateral movement (i.e. diagonal web).
- 7) Gable studs spaced at 2-0-0 oc.
- 8) This truss has been designed for a 10.0 psf bottom chord live load nonconcurrent with any other live loads.
- 9) * This truss has been designed for a live load of 20.0psf on the bottom chord in all areas where a rectangle 3-06-00 tall by 2-00-00 wide will fit between the bottom chord and any other members.
- 10) Provide mechanical connection (by others) of truss to bearing plate capable of withstanding 32 lb uplift at joint 5, 8 lb uplift at joint 3 and 29 lb uplift at joint 4.
- 11) Graphical purlin representation does not depict the size or the orientation of the purlin along the top and/or bottom chord.

LOAD CASE(S) Standard



October 3, 2025

WARNING - Verify design parameters and READ NOTES ON THIS AND INCLUDED MITEK REFERENCE PAGE MII-7473 rev. 1/2/2023 BEFORE USE.

Design valid for use only with MiTek® connectors. This design is based only upon parameters shown, and is for an individual building component, not a truss system. Before use, the building designer must verify the applicability of design parameters and properly incorporate this design into the overall building design. Bracing indicated is to prevent buckling of individual truss web and/or chord members only. Additional temporary and permanent bracing is always required for stability and to prevent collapse with possible personal injury and property damage. For general guidance regarding the fabrication, storage, delivery, erection and bracing of trusses and truss systems, see **ANSI/TPI1 Quality Criteria and DSB-22** available from Truss Plate Institute (www.tpinst.org) and **BCSI Building Component Safety Information** available from the Structural Building Component Association (www.sbcsccomponents.com)

MiTek®

400 Sunrise Ave., Suite 270
Roseville, CA 95661
916.755.3571 / MiTek-US.com

Job J1183948	Truss Z04B	Truss Type Blocking Supported Gable	Qty 6	Ply 1	NW Eastside Builders LLC Job Reference (optional)	R90572919
-----------------	---------------	--	----------	----------	--	-----------

The Truss Company (Sumner, WA), Sumner, WA - 98390,

Run: 25.30 S Sep 17 2025 Print: 25.3.0 S Sep 17 2025 MiTek Industries, Inc. Thu Oct 02 17:24:51
ID:xm?QLkXR3JlgpBZUI684o6z980z-RfC?PsB70Hq3NSgPqnL8w3uITxBkGkWrCDoi7J4zJC?f

Page: 1

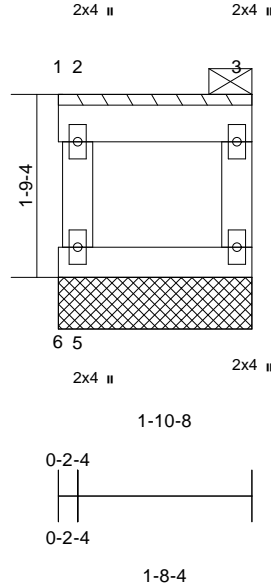

Scale = 1:22.3

Loading	(psf)	Spacing	2-0-0	CSI	DEFL	in	(loc)	l/defl	L/d	PLATES	GRIP	
TCLL	25.0	Plate Grip DOL	1.15	TC	0.05	Vert(LL)	n/a	-	n/a	999	MT20	220/195
(Roof Snow = 25.0)		Lumber DOL	1.15	BC	0.06	Vert(CT)	n/a	-	n/a	999		
TCDL	8.0	Rep Stress Incr	YES	WB	0.02	Horz(CT)	0.00	4	n/a	n/a		
BCLL	0.0*	Code	IRC2021/TPI2014	Matrix-MS								
BCDL	7.0										Weight: 9 lb	FT = 20%

LUMBER

TOP CHORD 2x6 DF SS
BOT CHORD 2x4 DF Stud
WEBS 2x4 DF Stud

BRACING

TOP CHORD 2-0-0 oc purlins: 1-3, except end verticals.
BOT CHORD Rigid ceiling directly applied or 10-0-0 oc bracing.

REACTIONS (size)

4=1-10-8, 5=1-10-8
Max Horiz 5=36 (LC 9)
Max Uplift 4=-14 (LC 7), 5=-27 (LC 6)
Max Grav 4=61 (LC 1), 5=78 (LC 1)

FORCES (lb) - Maximum Compression/Maximum Tension

TOP CHORD 1-2=0/0, 2-3=0/0, 3-4=-50/40
BOT CHORD 5-6=0/0, 4-5=-36/57
WEBS 2-5=-64/65

NOTES

- 1) Wind: ASCE 7-16; Vult=110mph (3-second gust)
Vasd=87mph; TCDL=4.8psf; BCDL=4.2psf; h=25ft; Cat. II; Exp B; Partially Enclosed; MWFRS (envelope) exterior zone and C-C Corner (3) zone; cantilever left and right exposed; end vertical left and right exposed; C-C for members and forces & MWFRS for reactions shown; Lumber DOL=1.60 plate grip DOL=1.60
- 2) Truss designed for wind loads in the plane of the truss only. For studs exposed to wind (normal to the face), see Standard Industry Gable End Details as applicable, or consult qualified building designer as per ANSI/TPI 1.
- 3) TCLL: ASCE 7-16; Pf=25.0 psf (Lum DOL = 1.15 Plate DOL = 1.15); Is=1.0; Rough Cat B; Partially Exp.; Ce=1.0; Cs=1.00; Ct=1.10
- 4) Provide adequate drainage to prevent water ponding.
- 5) Gable requires continuous bottom chord bearing.
- 6) Truss to be fully sheathed from one face or securely braced against lateral movement (i.e. diagonal web).
- 7) Gable studs spaced at 2-0-0 oc.

- 8) This truss has been designed for a 10.0 psf bottom chord live load nonconcurrent with any other live loads.
 - 9) * This truss has been designed for a live load of 20.0psf on the bottom chord in all areas where a rectangle 3-06-00 tall by 2-00-00 wide will fit between the bottom chord and any other members.
 - 10) Provide mechanical connection (by others) of truss to bearing plate capable of withstanding 14 lb uplift at joint 4 and 27 lb uplift at joint 5.
 - 11) Graphical purlin representation does not depict the size or the orientation of the purlin along the top and/or bottom chord.
- LOAD CASE(S)** Standard



October 3, 2025

WARNING - Verify design parameters and READ NOTES ON THIS AND INCLUDED MITEK REFERENCE PAGE MII-7473 rev. 1/2/2023 BEFORE USE.

Design valid for use only with MiTek® connectors. This design is based only upon parameters shown, and is for an individual building component, not a truss system. Before use, the building designer must verify the applicability of design parameters and properly incorporate this design into the overall building design. Bracing indicated is to prevent buckling of individual truss web and/or chord members only. Additional temporary and permanent bracing is always required for stability and to prevent collapse with possible personal injury and property damage. For general guidance regarding the fabrication, storage, delivery, erection and bracing of trusses and truss systems, see **ANSI/TPI1 Quality Criteria and DSB-22** available from Truss Plate Institute (www.tpinst.org) and **BCSI Building Component Safety Information** available from the Structural Building Component Association (www.sbcsccomponents.com)

MiTek®

400 Sunrise Ave., Suite 270
Roseville, CA 95661
916.755.3571 / MiTek-US.com

Symbols

PLATE LOCATION AND ORIENTATION

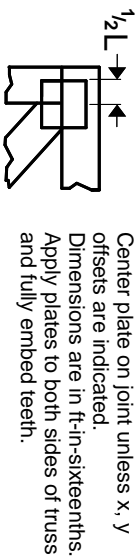

Center plate on joint unless x, y offsets are indicated. Dimensions are in ft-in-sixteenths. Apply plates to both sides of truss and fully embed teeth.

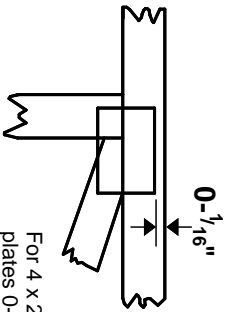

For 4 x 2 orientation, locate plates 0- 1/16\"/>



This symbol indicates the required direction of slots in connector plates.

* Plate location details available in MITtek software or upon request.

PLATE SIZE

4 X 4

The first dimension is the plate width measured perpendicular to slots. Second dimension is the length parallel to slots.

LATERAL BRACING LOCATION



Indicated by symbol shown and/or by text in the bracing section of the output. Use T or I bracing if indicated.

BEARING

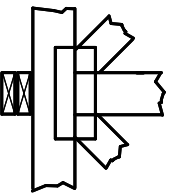

Indicates location where bearings (supports) occur. Icons vary but reaction section indicates joint number/letter where bearings occur. Min size shown is for crushing only.

Industry Standards:

ANSI/TFP1: National Design Specification for Metal Plate Connected Wood Truss Construction.
DSB-22: Design Standard for Bracing.
BCSI: Building Component Safety Information, Guide to Good Practice for Handling, Installing, Restraining & Bracing of Metal Plate Connected Wood Trusses.

Numbering System

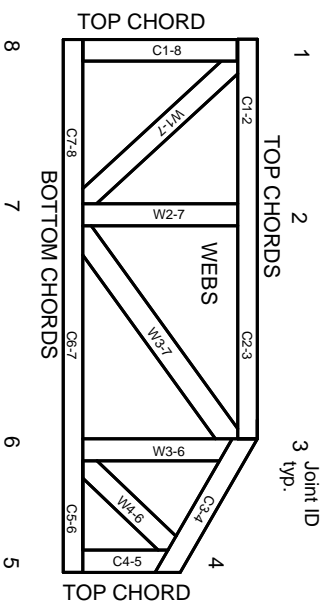

JOINTS ARE GENERALLY NUMBERED/LETTERED CLOCKWISE AROUND THE TRUSS STARTING AT THE JOINT FARTHEST TO THE LEFT.

CHORDS AND WEBS ARE IDENTIFIED BY END JOINT NUMBERS/LETTERS.

Product Code Approvals

ICC-ES Reports:

ESR-1-1988, ESR-2362, ESR-2685, ESR-3282
ESR-4722, ESL-1388

Design General Notes

Trusses are designed for wind loads in the plane of the truss unless otherwise shown.

Lumber design values are in accordance with ANSI/TFP 1 section 6.3. These truss designs rely on Lumber values established by others.

© 2023 MITtek® All Rights Reserved

General Safety Notes

Failure to Follow Could Cause Property Damage or Personal Injury

1. Additional stability/bracing for truss system, e.g. diagonal or X-bracing, is always required. See BCSI.
2. Truss bracing must be designed by an engineer. For wide truss spacing, individual lateral braces themselves may require bracing, or alternative Tor I bracing should be considered.
3. Never exceed the design loading shown and never stack materials on inadequately braced trusses.
4. Provide copies of this truss design to the building designer, erection supervisor, property owner and all other interested parties.
5. Cut members to bear tightly against each other.
6. Place plates on each face of truss at each joint and embed fully. Knots and wane at joint locations are regulated by ANSI/TFP 1.
7. Design assumes trusses will be suitably protected from the environment in accord with ANSI/TFP 1.
8. Unless otherwise noted, moisture content of lumber shall not exceed 19% at time of fabrication.
9. Unless expressly noted, this design is not applicable for use with fire retardant, preservative treated, or green lumber.
10. Camber is a non-structural consideration and is the responsibility of truss fabricator. General practice is to camber for dead load deflection.
11. Plate type, size, orientation and location dimensions indicated are minimum plating requirements.
12. Lumber used shall be of the species and size, and in all respects, equal to or better than that specified.
13. Top chords must be sheathed or purlins provided at spacing indicated on design.
14. Bottom chords require lateral bracing at 10 ft. spacing, or less, if no ceiling is installed, unless otherwise noted.
15. Connections not shown are the responsibility of others.
16. Do not cut or alter truss member or plate without prior approval of an engineer.
17. Install and load vertically unless indicated otherwise.
18. Use of green or treated lumber may pose unacceptable environmental, health or performance risks. Consult with project engineer before use.
19. Review all portions of this design (front, back, words and pictures) before use. Reviewing pictures alone is not sufficient.
20. Design assumes manufacture in accordance with ANSI/TFP 1 Quality Criteria.
21. The design does not take into account any dynamic or other loads other than those expressly stated.

MITek®

MITtek Engineering Reference Sheet: Mill-7473 rev. 1/2/2023